

Time to break new grounds
and increase your productivity.
Diana Go 85.



Full flexibility with small footprint. **Diana Go 85.**

The Diana Go was developed on the basis of market requirements of HEIDELBERG® by the Masterwork development team in Neuss, Germany. For both commercial and packaging printers, it is a cost-effective, flexible and productive entry-level machine with comparatively little space requirements. It can run a wide range of carton styles such as straightline and lockbottom as well as optionally special styles such as envelopes or CD covers. The Diana Go is able to hit a top speed of 250 m/min (300 m/min optional) in a machine just over nine meters (354.33 in) long.

The optionally integrated glue, inspection, and ejector systems ensure high production quality. Designed for customers needing higher productivity and the ability to offer an expanded portfolio of products to their clients, the Diana Go is attractively priced to ensure a high return on investment in a very competitive market. As a result of technology transfer, the Diana Go has many design features present in the high-performance folder gluers of the Diana series to ensure reliable performance and peace of mind.

Coming less than two years after the introduction of the successful Diana Easy, the Diana Go has now been added to the portfolio of postpress machines. The model completes the portfolio offered on folding carton gluers.

We can offer you the Diana Go as a compact valuelevel solution, the Diana Easy, a popular general purpose machine with more than 30 machines sold within 18 months, the Diana Smart, a 450 m/min workhorse, and the long established peak performance Diana X.

The Diana Go 85 is manufactured by Masterwork, exclusively distributed by HEIDELBERG and backed up by the professional and renowned, worldwide HEIDELBERG sales and service network.

➔ heidelberg.com/folding-carton-gluing

Outstanding characteristics. The facts at a glance.

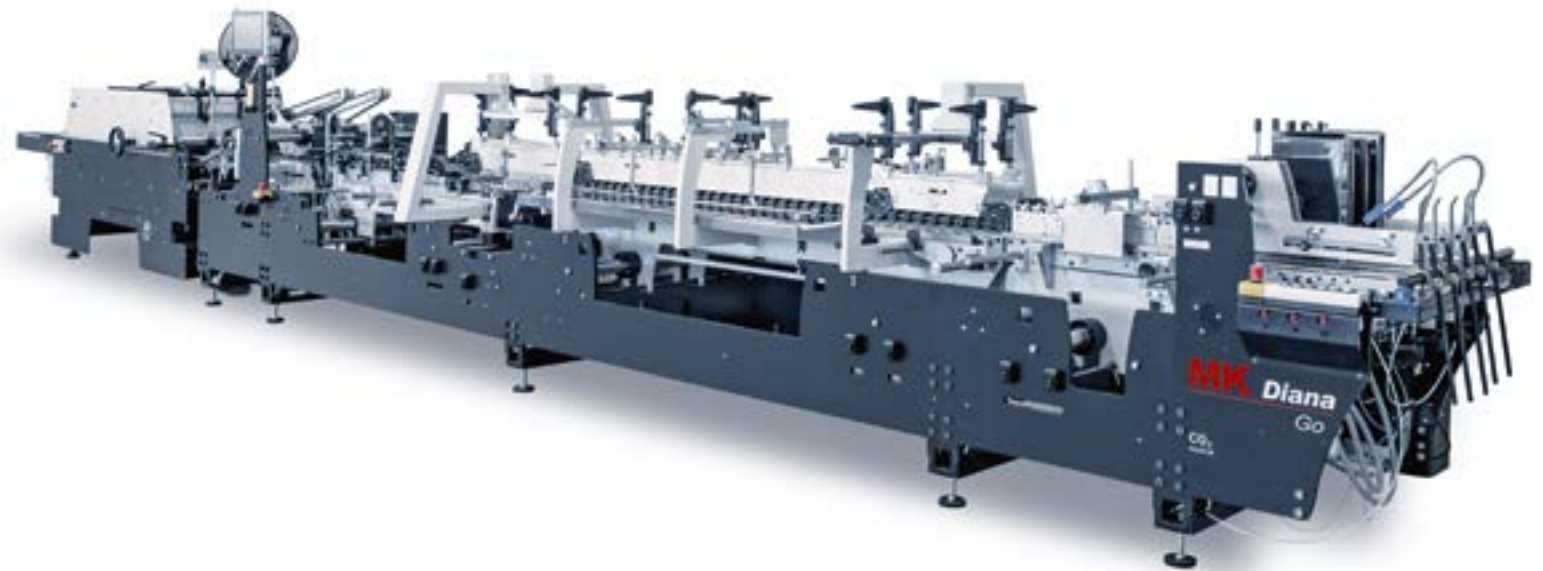

Highlights:

- Feeder with single servo drive
- Blank alignment (option)
- 2.30 m (90.55 in) prefolder
- Folding station with flexible roller bar design
- Transfer station with retrofittable blank ejection
- 2.9 m (114.17 in) collecting and pressing device (4 m (157.48 in) optional)
- State-of-the-art operating concept via touchscreen
- Excellent accessibility for easy setup
- Proven, reliable roller bar concept of the Diana series
- Solid machine run with very little vibration
- Intelligent belt guidance for greatly simplified belt exchange

➔ heidelberg.com/en/diana-go

Typical application examples and dimensions

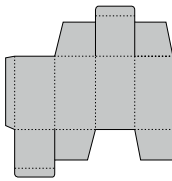
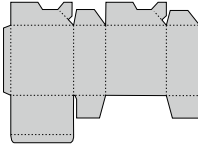
Applications ¹		Diana Go 85
Straightline carton		
W × L (max.)		850 × 400 mm (33.46 × 15.75 in)
W × L (min.)		75 × 90 mm (2.95 × 3.54 in)
W × L (min.) (with small carton device and alignment module)		45 × 55 mm (1.77 × 2.17 in)
Lockbottom carton²		
W × L (max.)		850 × 600 mm (33.46 × 23.62 in)
W × L (min.)		146 × 90 mm (5.75 × 3.54 in)
W × L (min.) (with alignment module)		146 × 80 mm (5.75 × 3.15 in)

¹Cartons out the above specifications can be evaluated on request.

²Please note the limitations and supplements for lockbottom cartons.

Technical Data

Processable materials	Diana Go 85
Max. speed	250 m/min (300 m/min optional)
Material (solid cardboard)	200 – 600 g/m ²
Material (corrugated cardboard)	up to F flute
Carton width (min.)	75 mm (45 mm optional) 2,95 in (1,77 in optional)
Carton width (max.)	850 mm (33.46 in)
Machine length (max.)	9,840 mm (387.40 in) (optional alignment module)
Weight	4.3 t

For value retention and maximum performance:

Service agreements

- Service agreements offer security and peace of mind, while at the same time providing you with the benefits of full cost control and simple administration
- Servicing by highly trained technicians
- Exclusive use of original service parts
- Protection of your machine investment
- Retention of a high resale value

→ [heidelberg.com/service-agreements](https://www.heidelberg.com/service-agreements)

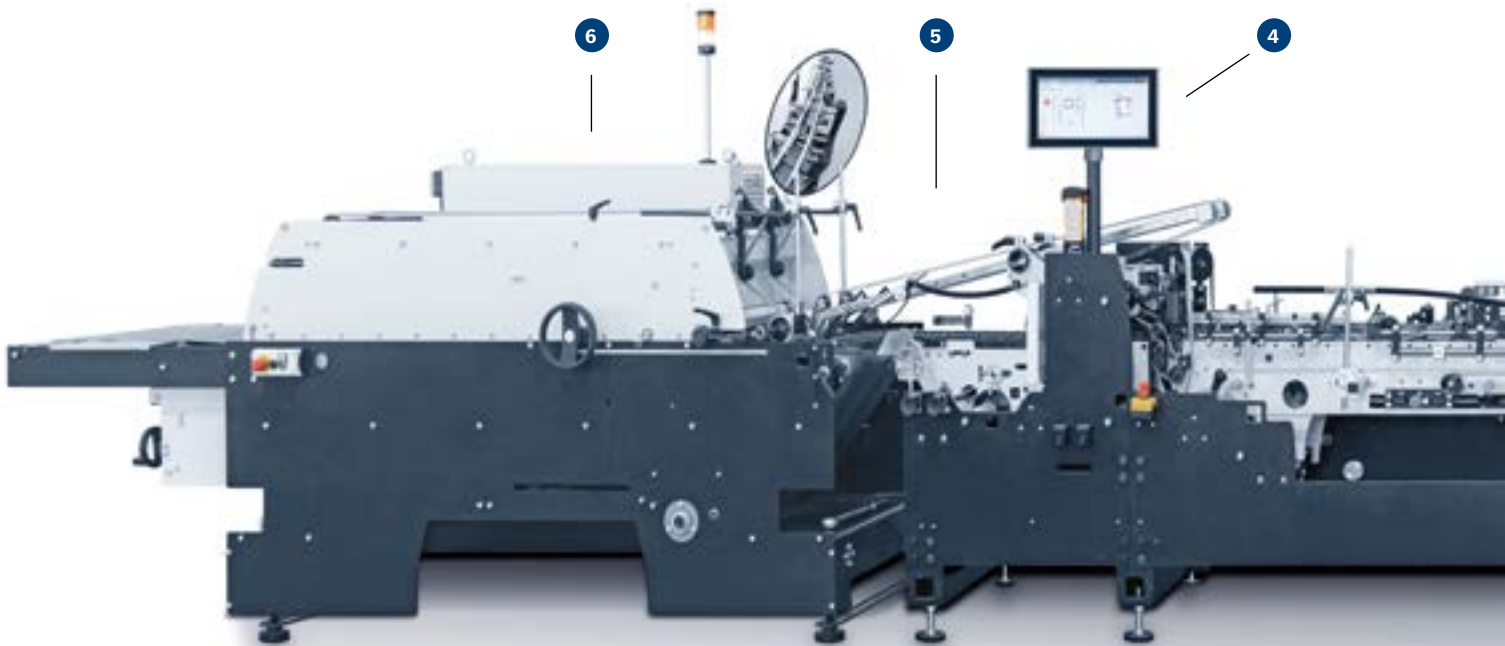

The machine shown is a sample configuration.
Some of the equipment features mentioned are optional.



1 Feeder and alignment

- Short setup times
- Friction feeder with quickly adjustable belt guides
- Belt change in less than 60 seconds without pulling the drive shaft
- Precise length and pressure adjustment of feeder gates for excellent control of even odd shaped cartons
- Vacuum feeder (option)
- Blank alignment (option)
- Blank alignment possible to the right or left side
- Alignment ruler adjustable sideways by up to 40 mm (1.57 in)



2 Prefolder

- Excellent accessibility thanks to low side panels on the operator and drive side
- Prefolding for crease lines 1 and 3
- Attachment of a code reader possible
- Lockbottom carton attachment (option)



3 Folding station

- Upper right and left blank carrier with slideable roller bars
- Left-before-right folding
- Center carrier as option: upper and lower roller bar can be easily installed and removed due to the light-weight design
- Belt folding possible with 45 mm (1.77 in) and open carton width (option)

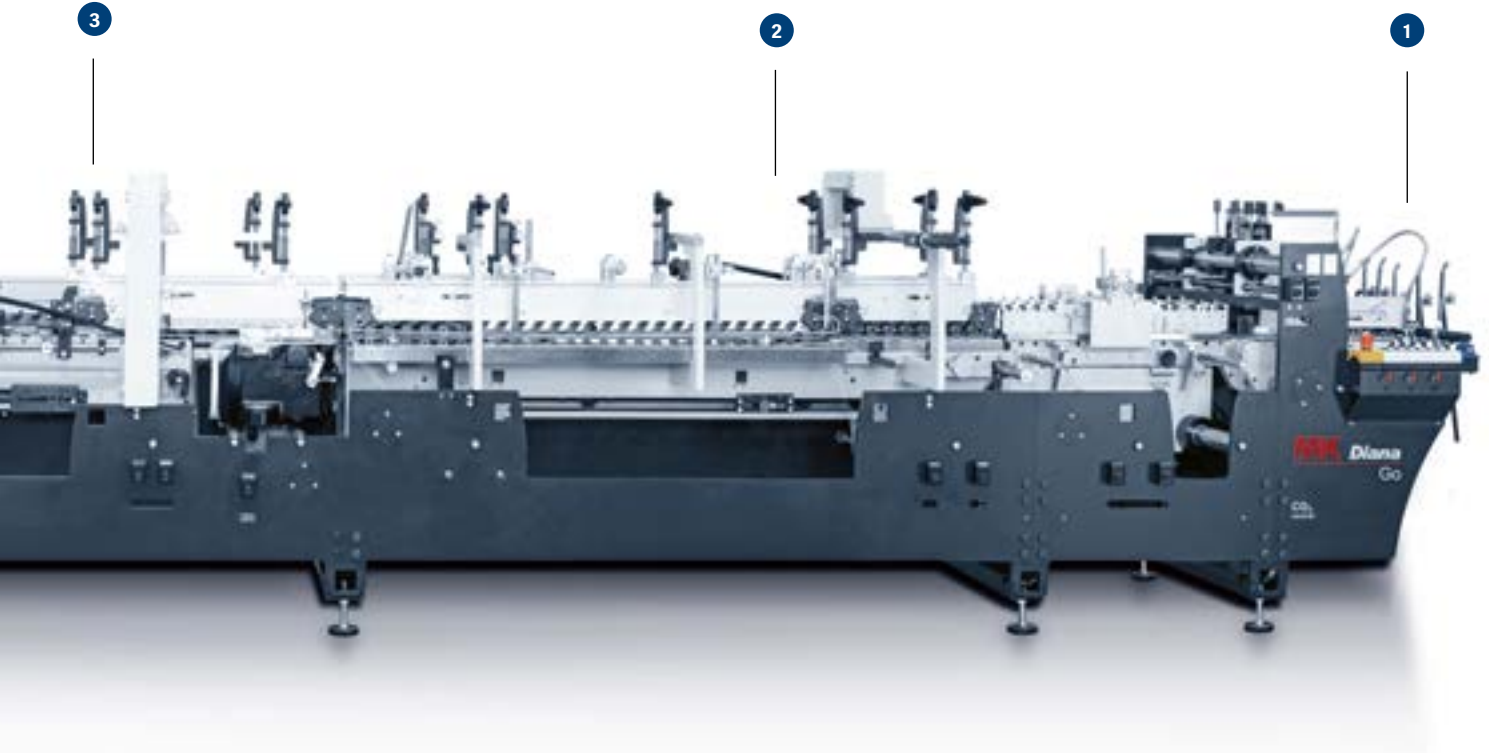

4 Machine user interface and automation

- Touchscreen for comfortable machine operation
- Easy, intuitive handling of machine interface with self-explanatory menu navigation
- ManuSet function



5 Transfer station

- Two upper and two lower blank carriers, each manually adjustable
- Blank ejection (option):
Linear ejector



6 Collecting and pressing station

- 600 mm (23.62 in) wide compression belt
- 1.6 m (62.99 in) pressing section
- Soft rubber belt for precise pressure compensation (option)
- Start/Stop function (option)

Features and benefits.

Diana Go 85.

Availability

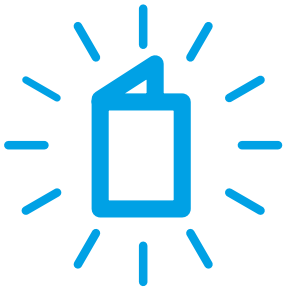

Additional equipment

Available for most carton styles: straightline, lockbottom, and mailing bags.

Machine design benefits from more than **100 Years** of experience in building folder gluers.

Upgradable.

Most additional equipment can be retrofitted.

Productivity



Up to
80,000
straightline cartons per hour.

Fast Processing.

Up to
250 
m/min

belt speed
(300 m/min option).

Wide range of products:

Smallest possible blank width

45 mm

Largest possible blank width

850 mm

User-Friendliness

Safe Operation.



Confirmed by GS certification.
Meets standards set by the German professional association ETEM (Energie Textil Elektro Medienerzeugnisse).

Fast change-over.

Low side panels ensure good accessibility.

Solid side panels.

Most robust construction in its class.

Publishing information

Sales and Service Partner:
Heidelberger Druckmaschinen AG
Kurfuersten-Anlage 52 – 60
69115 Heidelberg
Germany
Phone +49 6221 92-00
Fax +49 6221 92-6999
contact@heidelberg.com
Further details at:
heidelberg.com



Production note

Image credits: Heidelberger Druckmaschinen AG
Platemaking: Suprasetter
Printing: Speedmaster
Finishing: Stahlfolder
Consumables: Saphira

Printed in Germany

Trademarks

HEIDELBERG, the HEIDELBERG logotype are registered trademarks of Heidelberger Druckmaschinen AG in the U.S. and other countries. All other trademarks are property of their respective owners.

For details on the emissions of the Diana Go 85, please visit us at heidelberg.com/emissiondetails

Liability for contents

The contents of this brochure have been prepared with great care. No warranty or liability is accepted for the correctness, completeness, or accuracy of the information. There is no guarantee or warranty that the customer will be able to achieve the values and numbers (e.g. relating to the function and performance of the machine and the software) specified in the brochure. The information provided is based on ideal conditions and proper use of the machine and the software. Achieving these values and numbers depends on a variety of factors and circumstances that are outside the control of HEIDELBERG (e.g. machine settings, technical conditions, ambient conditions, raw materials and supplies used, consumables used, standard of care and maintenance of the machine, expertise of the operator, meeting the respective system requirements, etc.).

Version Nov 2023