

Improved performance
guaranteed.
Diana Easy 85/115.



Folding carton gluing made easy.



1878 Ferdinand Emil Jagenberg establishes a paper wholesale business in Düsseldorf

1930 The first Jagenberg folder gluer is built

1958 First folder gluer under the Diana brand

1971 Start of production at the new plant in Neuss, Germany

1994 Establishment of Jagenberg Diana GmbH

1999 Integration of WPM GmbH, supplier partnership with Jagenberg Slovensko, spol. s.r.o., Slovakia

2003 Integration into Heidelberger Druckmaschinen AG

2008 Launch of the new Diana generation with the Diana X 115, integration of folder gluer production in Nové Město, Slovakia

2014 Partnership of Heidelberger Druckmaschinen AG with MK Masterwork, China

The packaging market is subject to constant change. Modernization and adaptation to changes in the market are prerequisites for continued success in this competitive environment. In response to the changing needs of our customers, we have expanded our portfolio of folder gluers in the lower- to medium-performance segment with the Diana Easy from our partner Masterwork. The Diana Easy is not only the perfect machine for those getting started in the world of packaging, it is also a low-cost and efficient addition to existing machinery for professional packaging production.

The machine also offers a quick and convenient makeready process, a user-friendly design, and the highest quality standards. With a maximum speed of up to 350 m/min, the Diana Easy is perfectly equipped for handling a wide range of applications in the formats 85 cm (33.46 in) and 115 cm (45.28 in) and a carton length of up to 600 mm (23.62 in). Materials ranging from 200 – 600 g/m² for solid cardboard and E flute for corrugated cardboards can be processed.

An intelligent setup system based on a PLC control concept is available as an option to simplify previously labor-intensive and time-consuming setup processes. While the SmartSet function stores all the settings for repeat jobs for fast reproducibility, the DigiSet function calculates the positions of the roller carriers for initial makeready. In combination with the DriveSet function, the carriers can be conveniently moved by motor.

Retaining the design concept of the Diana X and Diana Smart model series means that a number of attachments and devices can also be used in the Diana Easy and vice versa.

The Diana Easy can be combined with the Pile Turner, the Diana Feeder, or a semi-automatic packing aid. This helps to greatly simplify the handling of materials around the machine, improve the production workflow, and reduce labor costs.

The machine offers a comprehensive range of quick and cost-effective retrofit options, such as:

- Backfolding shafts to produce 4-corner and 6-corner collapsible cartons
- Center carriers in prefolder and folding station
- Inline ejection system
- Running performance upgrade to 350 m/min

The Diana Easy 85/115 is manufactured by Masterwork, exclusively distributed by HEIDELBERG® and backed up by the professional and renowned, worldwide sales and service network HEIDELBERG.

➔ [heidelberg.com/folding-carton-gluing](https://www.heidelberg.com/folding-carton-gluing)

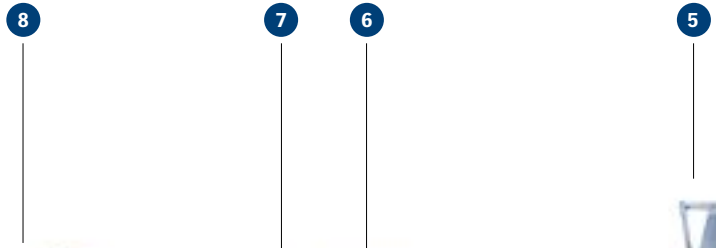

The machine shown is a sample configuration.
Some of the equipment features mentioned are optional.



1 Feeder with blank alignment

- Short setup times
- Friction feeder with quickly adjustable belt guides
- Belt change in less than 60 seconds without pulling the drive shaft
- Carriers adjustable in length
- Vacuum feeder (option)
- Blank alignment included in the basic model
- Blank alignment to the right or left side possible
- Alignment ruler adjustable sideways by up to 50 mm (1.97 in)
- Upper/lower center carrier in the blank alignment module (option)



2 Diana Inspector (option)

- Full inline inspection of the entire print image
- Suction tape technology stabilizes the blank for inspection
- Inspection of defined areas with different resolutions
- Inspection of hot-foils, aluminum-laminated materials and other highly reflective surfaces
- Setting values can be saved for repeat jobs
- Measurement of color variations greater delta 2.5
- Automatic ejection of defective or skew cartons possible
- Automated reporting
- Reliable carton transport
- Low energy consumption (LED lighting)
- PDF comparison for improved inspection quality



3 Prefolder

- Excellent accessibility thanks to low side panels on the operator and drive side
- Prefolding for crease lines 1 and 3
- Center carriers (retrofitable as an option)

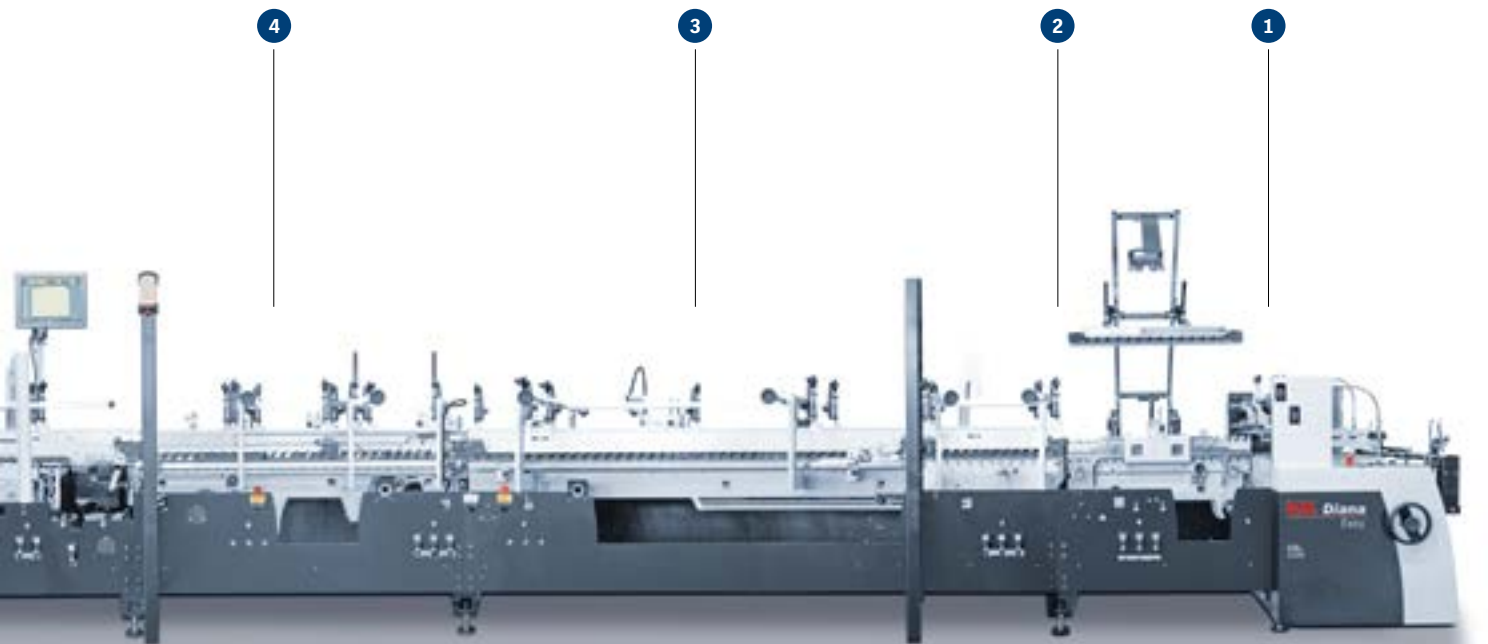

4 Combi module

- Three lower carriers and five upper roller bars
- Attachment for collapsible cartons available or retrofittable (option)
- Lockbottom attachment as standard
- Safety light barrier concept for maximum operational safety without limiting accessibility



5 Folding station

- Right and left blank carrier with telescopic roller bars
- Left-before-right folding or right-before-left folding as standard
- Center carrier (option) upper roller bar collapsible, lower roller bar easy to install and remove thanks to the light-weight design
- Belt folding possible with 45 mm (1.77 in) and open carton width (option)



6 Machine user interface and automation

- Touchscreen for machine operation
- Inline inspection for full print image and foil monitoring
- Easy, intuitive handling of machine interface with self-explanatory menu navigation
- SmartSet: Positioning can be stored for repeat jobs (option)
- DigiSet: Automatic advance calculation of all carrier positions, settings can be saved for repeat jobs (option)
- DriveSet for the motorized movement of roller bars (option)

Outstanding characteristics.

The facts at a glance.

Highlights:

- Feeder with single servo drive
 - Blank alignment as standard
 - 3 m (118.11 in) prefolder
 - Combi module with the latest safety concept for collapsible cartons
 - Folding station with ultra-flexible roller bar design
 - Transfer station with retrofittable blank ejection
 - 4 m (157.48 in) collecting and pressing device
 - Inline inspection of folding cartons with Diana Inspector
- State-of-the-art operating concept via touchscreen
 - Excellent accessibility for easy setup
 - Proven, reliable roller bar design of the Diana series
 - Solid machine run with very little vibration
 - Intelligent belt guidance for greatly simplified belt exchange

→ heidelberg.com/en/diana-easy



7 Transfer station

- Two upper and two lower blank carriers
- Upper carriers adjustable manually, lower carriers by motor
- Inline blank ejection also retrofittable (option)
- Touchscreen for comfortable machine operation



8 Collecting and pressing station

- 600 mm (23.62 in) wide compression belt
- 2.4 m (94.49 in) pressing section
- Soft rubber belt for precise pressure compensation (option)
- Start/Stop function (option)

For value retention and maximum performance:

Service agreements

- Service agreements offer security and peace of mind, while at the same time providing you with the benefits of full cost control and simple administration
- Servicing by highly trained technicians
- Exclusive use of original service parts
- Protection of your machine investment
- Retention of a high resale value

→ heidelberg.com/service-agreements

Typical application examples and dimensions

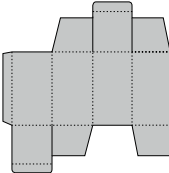
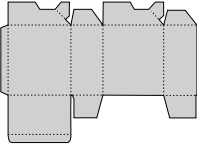
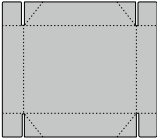
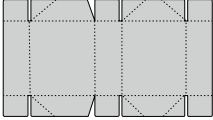
Applications		Diana Easy 85	Diana Easy 115
Straightline carton		850 × 600 mm (33.46 × 23.62 in)	1,150 × 600 mm (45.28 × 23.62 in)
W × L (max.)		75 × 55 mm (2.95 × 2.17 in)	75 × 55 mm (2.95 × 2.17 in)
W × L (min.)		45 × 55 mm (1.77 × 2.17 in)	45 × 55 mm (1.77 × 2.17 in)
W × L (min.) (with small carton device)			
Lockbottom carton		800 × 600 mm (31.50 × 23.62 in)	1,150 × 600 mm (45.28 × 23.62 in)
W × L (max.)		146 × 55 mm (5.75 × 2.17 in)	146 × 55 mm (5.75 × 2.17 in)
W × L (min.)			
4-corner collapsible carton		850 × 680 mm (33.46 × 26.77 in)	880 × 680 mm (34.65 × 26.77 in)
W × L (max.)		120 × 110 mm (4.72 × 4.33 in)	120 × 110 mm (4.72 × 4.33 in)
W × L (min.)			
6-corner collapsible carton		850 × 630 mm (33.46 × 24.8 in)	1,150 ¹ × 630 mm (45.28 × 24.8 in)
W × L (max.)		250 × 130 mm (9.84 × 5.12 in)	250 × 130 mm (9.84 × 5.12 in)
W × L (min.)			

¹With transversely adjustable outfeed only.

Technical Data

Processable materials	Diana Easy 85	Diana Easy 115
Max. speed	300 m/min (350 m/min optional) 300 m/min (350 m/min optional)	
Material (solid cardboard)	200 – 600 g/m ²	200 – 600 g/m ²
Material (corrugated cardboard)	up to E flute	up to E flute
Carton width (min.)	45 mm (1.77 in) (option)	45 mm (1.77 in) (option)
Carton width (max.)	850 mm (33.46 in)	1,150 mm (45.28 in)

Features and benefits.

Diana Easy 85/115.

Availability

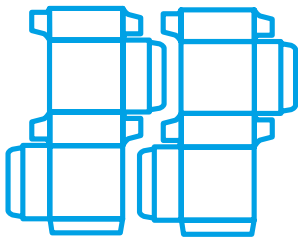

17%

more space for high-quality folding cartons. **Longest** folder gluer in its class.

Attachments available for all common carton styles.

Upgradable, most additional equipment can be retrofitted, even for 4-/6-corner collapsible cartons.

More than **100 Years** of experience in building folder gluers.

Productivity



Fast Processing.

Up to

350

 m/min

belt speed.

Wide range of products:

Smallest possible **blank width 45 mm** (1,77 in) (open) Largest possible **blank width 850/1,150 mm.**

More than **100,000** straightline cartons per hour.

User-friendliness

SmartSet.

Stores job data and saves makeready times.



Safe Operation. Confirmed by GS certification.

DigiSet.

Reduces makeready time by

50 %.

Sales and Service Partner:
Heidelberger Druckmaschinen AG
Heidelberger Druckmaschinen AG
Kurfuersten-Anlage 52 – 60
69115 Heidelberg
Germany
Phone +49 6221 92-00
Fax +49 6221 92-6999
contact@heidelberg.com
Further details at:
heidelberg.com



Production note

Image credits: Heidelberger Druckmaschinen AG
Platemaking: Suprasetter
Printing: Speedmaster
Finishing: Stahlfolder
Consumables: Saphira

Printed in Germany

Trademarks

HEIDELBERG, the HEIDELBERG logotype are registered trademarks of Heidelberger Druckmaschinen AG in the U.S. and other countries. All other trademarks are property of their respective owners.

For details on the emissions of the Diana Easy 85/115, please visit us at heidelberg.com/emissiondetails

Liability for contents

The contents of this brochure have been prepared with great care. No warranty or liability is accepted for the correctness, completeness, or accuracy of the information. There is no guarantee or warranty that the customer will be able to achieve the values and numbers (e.g. relating to the function and performance of the machine and the software) specified in the brochure. The information provided is based on ideal conditions and proper use of the machine and the software. Achieving these values and numbers depends on a variety of factors and circumstances that are outside the control of HEIDELBERG (e.g. machine settings, technical conditions, ambient conditions, raw materials and supplies used, consumables used, standard of care and maintenance of the machine, expertise of the operator, meeting the respective system requirements, etc.).

Version Nov 2023