

Great performance
in a small space.
Diana Pharma.



Folding, gluing, embossing. Produce short runs with ease.

Diana Pharma – the combination of easy operation and powerful embossing module from HEIDELBERG.

With the Diana Pharma folding carton gluing machine from HEIDELBERG®, you are ideally equipped to meet the requirements of the pharmaceutical industry. The machine was developed by Masterwork specifically for this market and is distributed exclusively by HEIDELBERG. It processes a wide range of all standard pharmaceutical packaging such as straightline and lockbottom – quickly and in a small space. The special feature: the machine is equipped with a Braille module that allows you to emboss at speeds of up to 250 m/min. This allows you to increase your production output – even with short runs, as the machine can be converted quickly and easily.

Benefit from the many advantages of automation: the machine is prepared for connection of our peripherals Diana Feeder, Diana Easypacker and Diana Smartpacker. Shorten your set-up times with the simple positioning of the Braille systems, the Easy Set setting support and the intuitive machine control on the HMI (Human Machine Interface).

When you choose HEIDELBERG, you get more than just a folding carton gluing machine. You gain access to an ecosystem that offers you real added value – with service, consumables, digital services, software, training and consulting. We will accompany you into the future.



→ [heidelberg.com](https://www.heidelberg.com)

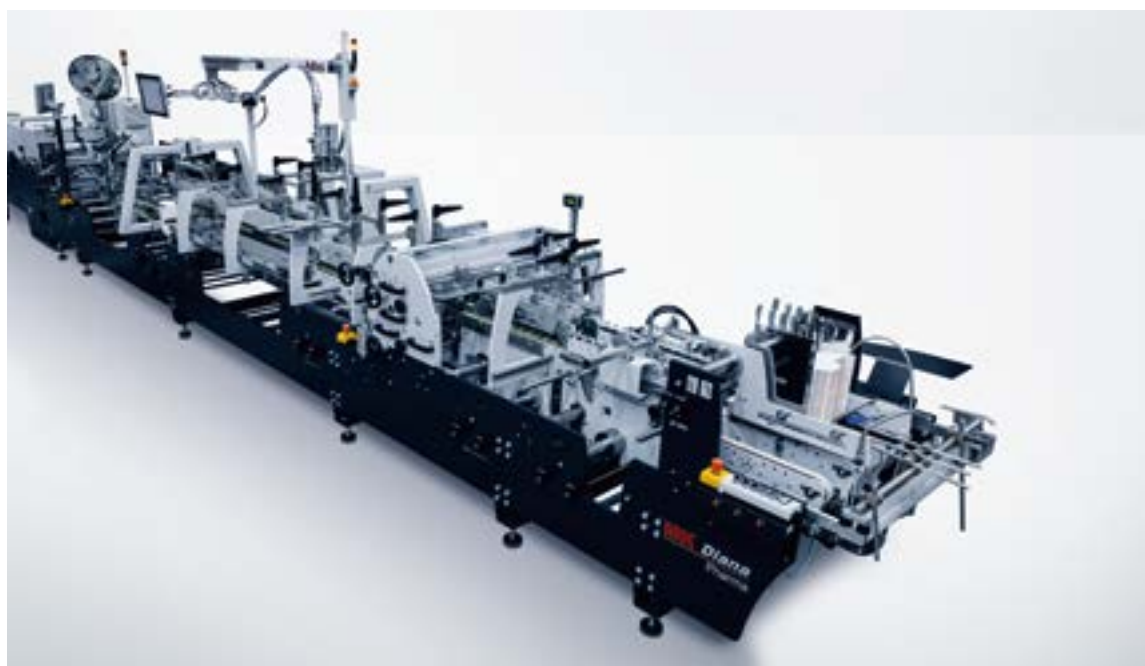

DIANA PHARMA

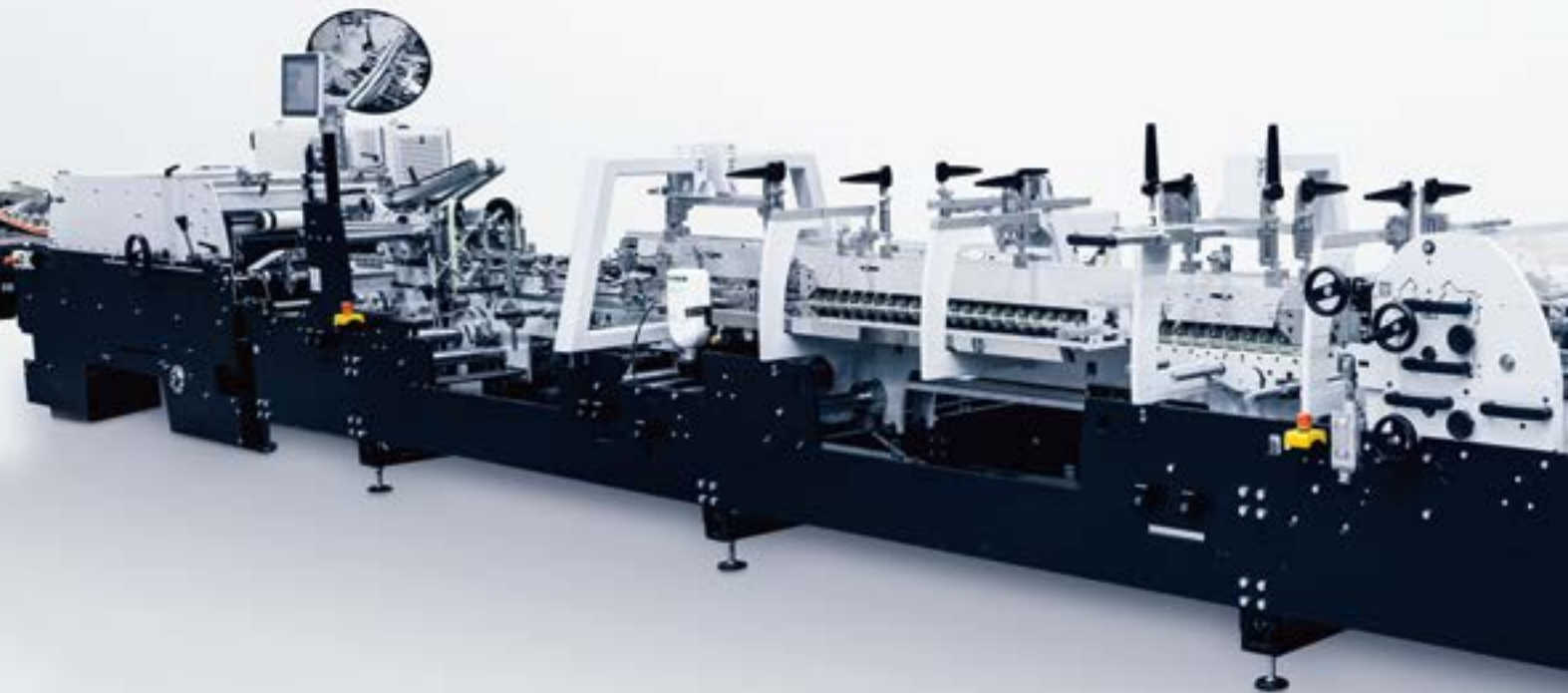

Remote maintenance for fast support is already included in the basic machine thanks to the MK remote module of MK Masterwork



The **interfaces for connecting peripheral devices** upstream or downstream of the Diana Pharma included as standard facilitate the handling of blanks at high production speeds.



The **compact design** of the machine and intelligent user interface make for easy set-up and simple operation.

MA



The **Braille module** embosses at a machine speed of up to 250 m/min.

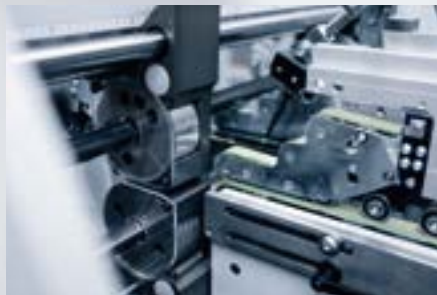

The **digital position control of the Braille tools** ensures precise positioning of the embossing and therefore enables production reliability.



Feeder and blank alignment ensure precise and stable carton feeding with reliable carton alignment.

9

Interfaces to Diana peripherals

Interfaces to the Diana Feeder, Diana Easypacker and Diana Smartpacker enable quick and uncomplicated connection of additional devices.

7

Collecting and pressing station

The pressing station with its 600 millimetre wide pressing belt and large pressing section offers the option of making manual adjustments to the respective pressure zones. Equipped with electronic speed control, it adapts seamlessly to different production speeds. Optional soft rubber belts ensure local pressure compensation.

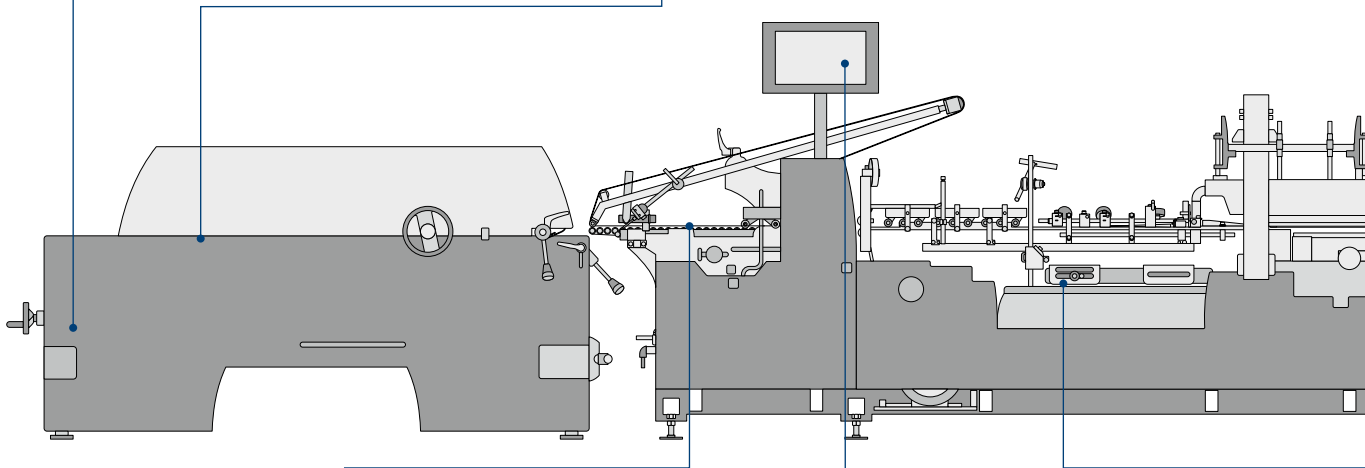

6

Transfer station

With its manual adjustment of the upper and lower roller bars, the transfer station offers flexible gap options. The linear ejector accurately sorts out faulty folding cartons.

8

User interface

Self-explanatory and user-friendly menu navigation allows quick and easy familiarisation with the machine concept. Even seemingly complex settings for the Braille module are displayed in an intuitively understandable way.

4

Prefolding station

The prefolding station ensures precise prefolding for crease lines 1 and 3 and facilitates the subsequent processing of the folding cartons. Different print profiles being mixed by attaching an optional barcode scanner.

2

Blank alignment module

The alignment module improves the accuracy of the embossing, gluing and folding. With its precise alignment to the drive or operator side, it ensures the quality of the folding cartons.

1

Feeder

With four belt guides, two main feed gates with transport carriage extension and electronic control, the feeder optimises the precise feeding of blanks and therefore improves the efficiency of your production.

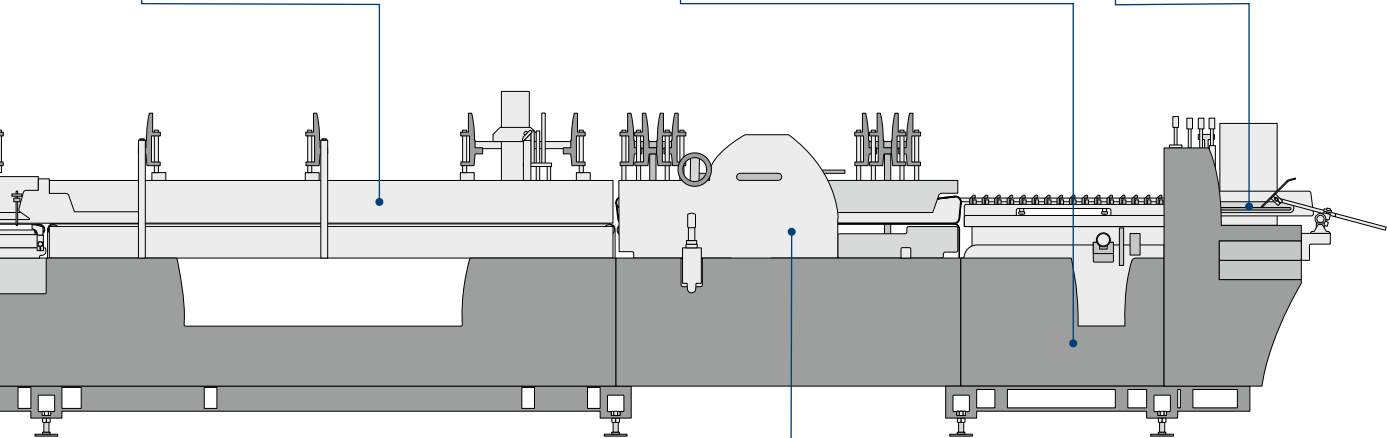

5

Folding station

The folding station is easily accessible for the operator and offers a high degree of flexibility thanks to laterally and longitudinally adjustable roller bars and guide rollers. This, in combination with the high-precision bottom gluing unit, ensures consistently high quality during folding and gluing of your folding cartons.

3

Braille module

Thanks to its unique transverse positioning across the entire working width and the position display, the Braille module ensures millimetre-precise alignment of the Braille embossing and a fast set-up process. The double-sheet control prevents incorrect settings in the feeder.



You can find further information and technical details for your Diana Pharma here:

➔ heidelberg.com/en/diana-pharma

Compact design, impressive efficiency.



With the Diana Pharma, you are well-equipped to meet the demands of the pharmaceutical industry. Its high level of automation reduces sources of error and therefore enables the uncomplicated production of packaging in short runs.

Simple and easy to operate

Compact design

At less than 12 metres, the compact design of the Diana Pharma enables fast set-up times through short walking distances. Semi-automatic functions ensure fast learning and user-friendly operation.



→ heidelberg.com/en/diana-pharma

Precise folding and gluing

Folding station

The Diana Pharma is the entry-level folding carton gluing machine for standard pharmaceutical designs such as straightline and lockbottom cartons. Precise folding and gluing ensure high production reliability.

Precise and powerful embossing

Braille module

The Braille module allows you to meet the standards required by the pharmaceutical industry. The Diana Pharma applies Braille to folding cartons at speeds of up to 250 m/min – quickly and accurately.

Quick and uncomplicated changeover

Embossing, folding and gluing

An ergonomic operating concept, sophisticated clamping systems and high-quality folding elements allow quick and easy changeovers. Whilst and well-arranged machine modules make operation even easier for you.

Simple connection for greater efficiency

Diana Feeder, Diana Easypacker and Smartpacker

Take advantage of the opportunity to process orders simply, quickly and without increased labour costs. Connect peripheral devices and get the most out of your Diana Pharma.



→ heidelberg.com/en/diana-packer-series

Publishing information

Heidelberger Druckmaschinen AG
Kurfuersten-Anlage 52 – 60
69115 Heidelberg
Germany
Phone +49 6221 92-00
Fax +49 6221 92-6999
contact@heidelberg.com
Further details at:
heidelberg.com

Production note

Image credits: Heidelberger Druckmaschinen AG
Platemaking: SupraSetter
Printing: Speedmaster
Finishing: Stahlfolder
Consumables: Saphira

Printed in Germany**Trademarks**

HEIDELBERG, the HEIDELBERG logotype, Saphira, Speedmaster, Stahlfolder and SupraSetter are registered trademarks of Heidelberger Druckmaschinen AG in the U.S. and other countries. All other trademarks are property of their respective owners.

For details on the emissions of the Diana Pharma, please visit us at [heidelberg.com/emissiondetails](https://www.heidelberg.com/emissiondetails)

Liability for contents

The contents of this brochure have been prepared with great care. No warranty or liability is accepted for the correctness, completeness, or accuracy of the information. There is no guarantee or warranty that the customer will be able to achieve the values and numbers (e.g. relating to the function and performance of the machine and the software) specified in the brochure. The information provided is based on ideal conditions and proper use of the machine and the software. Achieving these values and numbers depends on a variety of factors and circumstances that are outside the control of HEIDELBERG (e.g. machine settings, technical conditions, ambient conditions, raw materials and supplies used, consumables used, standard of care and maintenance of the machine, expertise of the operator, meeting the respective system requirements, etc.).

Version Mar 2024