

INTERIM FINANCIAL REPORT

SECOND QUARTER 2007/2008

HEIDELBERG

PERFORMANCE OF THE HEIDELBERG SHARE

compared with the DAX/MDAX (Index: April 1, 2007 = 0 percent)



KEY PERFORMANCE DATA

Figures in € millions

	Q1 to Q2 prior year	Q1 to Q2 2007/2008	Q2 prior year	Q2 2007/2008
Incoming orders	1,996	1,866	920	932
Net sales	1,628	1,639	909	897
Result of operating activities¹⁾	118	96	102	70
– in percent of sales	7.2	5.9	11.2	7.8
Net profit¹⁾	68	44	63	36
– in percent of sales	4.2	2.7	6.9	4.0
Cash flow	94	97	64	69
– in percent of sales	5.8	5.9	7.0	7.7
Free cash flow¹⁾	–25	–43	69	38
Research and development costs	116	111	58	54
Investments	66	96	37	44
Earnings per share in €	0.83	0.57	0.77	0.47

¹⁾ Previous year's figures comprise positive one-time effects from the sale of Linotype GmbH

Contents

2 THE HEIDELBERG SHARE

3 CONSOLIDATED INTERIM MANAGEMENT REPORT

Overall Picture
Underlying Conditions
Business Development
Results of Operations,
Net Assets, and Financial Position
Heidelberg Excellence
Divisions
Regions
Research and Development
Employees
Risk and Opportunity Report
Future Prospects

16 THE SECOND QUARTER IN REVIEW

CONSOLIDATED INTERIM FINANCIAL STATEMENTS FOR THE PERIOD APRIL 1, 2007 TO SEPTEMBER 30, 2007

20	Interim Income Statement – April 1, 2007 to September 30, 2007
21	Interim Income Statement – July 1, 2007 to September 30, 2007
22	Interim Income Statement – Quarterly Overview
23	Interim Balance Sheet
25	Cash Flow Statement – April 1, 2007 to September 30, 2007
26	Cash Flow Statement – Quarterly Overview
27	Statement of Recognized Income and Expense
27	Development of Shareholders' Equity
28	Segment Information
30	Notes
40	RESPONSIBILITY STATEMENT BY THE MANAGEMENT BOARD
41	SUPERVISORY BOARD AND MANAGEMENT BOARD

The Heidelberg Share

Both of the major German share indexes – the DAX and the MDAX – continued to be strong at the beginning of the reporting quarter. By mid-July, the interplay of rising interest rates and falling real estate prices in the US resulted in greater credit losses and thus to the so-called subprime crisis, which exerted strong pressure on the German stock market as well. Despite their strengthening at the end of September, both indexes therefore suffered price declines during the past quarter.

Following the Heidelberg share's superior development compared with the indexes early in July, it was subsequently unable to escape the general stock market trend, and followed the negative tendency. At the end of the quarter, however, our share was unable to benefit from the renewed upward trend, and ended the quarter with a strong loss.

Our Annual General Meeting was held at Mannheim's Rosengarten Congress Center this year on July 26. Some 1,500 shareholders attended the event, representing approximately 63 percent of Heidelberg's share capital. Like all other proposals, the appropriation of distributable profit as well as the related payment of a dividend of € 0.95 were approved by a large majority.

The second share buyback program, which was launched in November 2006, was concluded on September 4, 2007. During this period we bought back a total of 4,152,535 shares, accounting for 5 percent of the share capital at the time the program was approved. Of this, 2,133,113 shares were still being held as treasury stock at the end of the reporting quarter, accounting for some 2.7 percent of outstanding shares.

KEY PERFORMANCE DATA OF THE HEIDELBERG SHARE

Figures in €

	Q2 prior year	Q2 2007/2008
Earnings per share	0.77	0.47
Cash flow per share	0.78	0.88
Share price – high	36.47	40.66
Share price – low	30.67	29.87
Share price – beginning of the quarter ¹⁾	36.33	36.17
Share price – end of the quarter ¹⁾	32.51	30.68
Market capitalization at the end of the quarter in € millions	2,700	2,446
Number of shares in thousands ²⁾	81,986	78,633

¹⁾ Xetra closing price; source of prices: Bloomberg

²⁾ Weighted number of outstanding shares

Overall Picture

Fortunately, the Chinese market recovered further during the second quarter. This contributed to the slight improvement in the Heidelberg Group's incoming orders over the previous year. Due to foreign currency-related developments, sales fell short of the previous year's level. Nevertheless, we continue to expect a modest growth in sales for the year as a whole. Our forecasts for other developments during the financial year as a whole also remain largely unchanged.

Underlying Conditions

The global economy continued to develop favorably, albeit at a slightly weaker pace. The critical development of the US financial and real estate markets as well as the continuing high energy prices are having a constraining effect. The global economy is still benefiting from a favorable impetus from the emerging markets and Europe. The financial market crisis in the US did not have the feared impact on European or Asian markets. Moreover, the long-term impact seems to be rather slight. As a result, this development is seen as a correction in the financial markets and a healthy, realistic adjustment in lending terms.

The continuing strong euro continues to burden German exports. However, domestic demand is benefiting from the favorable development of the job market and of salaries and wages, as well as from the ongoing high propensity to invest. Due to the vigorous growth, for the first time in quite some time the German Federal Government is projecting a nearly break-even budget for 2007.

The economic situation in Eastern Europe remains stable. Russia in particular continues to benefit from the high raw material prices. Latin America is also experiencing substantial growth in GDP, with negative developments arising only in countries whose economies are strongly linked with US markets. Asia is developing favorably. China, India, and many Southeast Asian markets continue to enjoy rapid economic growth.

The situation in the print media industry is still favorable. This is confirmed in the US printing industry by growth in production. Capacity utilization in the German printing industry rose during the second quarter.

Business climate indexes also remain stable. Exchange rate structures continue to reinforce competitive pressures among equipment suppliers to the print media industry, with the weak US dollar and the equally weak Japanese yen securing advantages for our Japanese competitors.

Business Development

INCOMING ORDERS BY DIVISION

2007/2008, Q1 to Q2

2006/2007, Q1 to Q2

Figures in € millions



Press	1,632	-7 %
Postpress	218	+1 %
Financial Services	16	-16 %
Heidelberg Group	1,866	-7 %
Press	815	+1 %
Postpress	109	+6 %
Financial Services	8	-11 %
Heidelberg Group	932	+1 %

The Heidelberg Group generated **incoming orders** of € 932 million during the second quarter – approximately the same level as in the previous year and in the previous quarter. We were able to generate marked growth in the Postpress Division – a favorable development. The further strengthening of the Chinese market, where we generated the third highest volume of orders during the reporting quarter after the US and Germany, is also gratifying. The unfavorable exchange rate situation caused by the weakness in the US dollar and the Japanese yen had a negative effect. Adjusted for foreign currency influences, the increase in incoming orders over the previous year amounted to 4 percent. In the first half-year, the Heidelberg Group's incoming orders reached a volume of € 1,866 million. Primarily due to the IPEX trade show, which had secured a particularly high level of incoming orders during the first quarter of the previous year, with -7 percent we are still considerably below the previous year's figure.

The **order backlog** totaled € 1,184 million as of September 30, 2007, down from the end of the previous quarter largely due to foreign currency factors. The order backlog currently extends to 3.7 months.

Our **sales** of € 897 million during the second quarter were slightly below the previous year's figure. This was again caused mainly by unfavorable exchange rate developments. After adjusting for foreign currency changes, we generated a modest increase in sales over the previous year. As in the case of incoming orders, the development of the Postpress Division was

favorable. As planned, the interest income of the Financial Services Division is declining. Of all the regions, only Eastern Europe posted growth. In the overall first half of the financial year, the Heidelberg Group generated sales for the period of € 1,639 million – only slightly above the previous year's figure.

SALES BY DIVISION

Figures in € millions

	Q1 to Q2 prior year	Q1 to Q2 2007/2008	Q2 prior year	Q2 2007/2008
Press	1,423	1,424	803	785
Postpress	186	199	97	104
Financial Services	19	16	9	8
Heidelberg Group	1,628	1,639	909	897

Results of Operations, Net Assets, and Financial Position

RESULT OF OPERATING ACTIVITIES

2007/2008, Q1 to Q2

2006/2007, Q1 to Q2

Figures in € millions

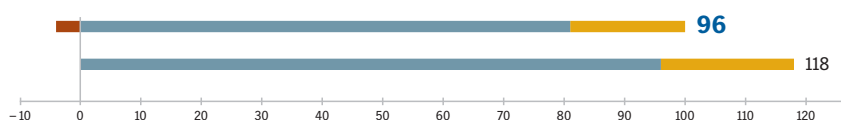

Press	81	96
Postpress	-4	0
Financial Services	19	22
Heidelberg Group	96	118
Press	60	92
Postpress	0	0
Financial Services	10	10
Heidelberg Group	70	102

The Heidelberg Group's **result of operating activities** reached € 70 million during the second quarter of the financial year. The decline from the previous year was caused largely by inclusion of the sale proceeds of Linotype GmbH in the previous year's figures. We continued to reduce our structural costs. We also slightly reduced the costs for research and development from the previous year. The slightly lower sales volume, negative foreign currency influences, higher personnel expenses due to a high collective bargaining agreement, and to the new hirings had a dampening effect. Although the Postpress Division was in the red during the first quarter, the division achieved a break-even result during the second quarter.

We thereby achieved a result of operating activities of € 96 million in the first half-year as a whole, with the operating return on sales amounting to nearly 6 percent.

The **financial result** for the first two quarters amounted to € -31 million (previous year: € -24 million), with net interest deteriorating due to higher interest rates. **Income before taxes** totaled € 65 million, with the tax rate at 31 percent. Overall, we therefore generated a **net profit** of € 44 million during the first half of the year. Earnings per share were € 0.57.

In the first half of the financial year we posted **investments** in tangible and intangible assets of € 96 million – up by approximately 45 percent. This increase was mainly attributable to investments in our new large-format printing press generation, which we will introduce at drupa 2008. The new assembly hall 11 at Wiesloch-Walldorf, where the new Speedmaster XL 145 and Speedmaster XL 162 will be assembled, was inaugurated mid-September. The overall volume of investment amounts to € 45 million, and was largely included in the figures of the first half-year.

The **total assets** of the Heidelberg Group of € 3,464 million at September 30, 2007 remained virtually unchanged during the second quarter.

Among assets, inventories further increased slightly over the previous quarter. By contrast, trade receivables and receivables from customer financing were in decline, with the latter totaling a further € 25 million less than the previous quarter's figure. Other assets additionally increased due to the favorable development of the balances in the pension funds.

BALANCE SHEET STRUCTURE

Figures in € millions

	31-Mar- 2007	in percent of total assets	30-Sep- 2007	in percent of total assets
Non-current assets	1,411	42	1,441	42
Current assets	1,928	58	2,023	58
Total assets	3,339	100	3,464	100
Shareholders' equity	1,202	36	1,155	33
Non-current liabilities	1,123	34	1,115	32
Current liabilities	1,014	30	1,194	35
Total equity and liabilities	3,339	100	3,464	100

Among liabilities, shareholders' equity of € 1,155 million is considerably below the figure for the end of the first quarter. Responsible for this development are the dividend payment in July 2007 following the Annual General Meeting as well as the effect of the second share buyback program that had been approved in September. Overall, 5 percent of the share capital was bought back under this program. As of September 30, 2007 the equity ratio amounted to approximately 33 percent. In order to cover the financial requirements for dividends and share buybacks, current financial liabilities rose further during the second quarter, with financial liabilities amounting to € 731 million as of the quarterly reporting date.

Cash flow reached € 97 million during the first half-year – slightly over the previous year's figure and reaching 6 percent of sales.

Compared with the same period the previous year, the outflow of funds from **other operating changes** was down – a result, among other things, of the lower outflow of working capital funds. We achieved particular improvement in our trade receivables. The **outflow of funds from investment activity** totaling € –85 million rose considerably. This figure had been favorably influenced in the previous year by the divestiture of subsidiaries. Furthermore, the investment volume was up significantly during the six-month reporting period due to the investment in assembly hall 11.

Overall, as a result, the **free cash flow** of € –43 million still fell short of the previous year's level during the first half-year. Nevertheless, during the second quarter free cash flow of € 38 million was already solidly in the black.

CASH FLOW STATEMENT

Figures in € millions

	Q1 to Q2 prior year	Q1 to Q2 2007/2008
Cash flow	94	97
Working capital	– 39	– 35
Receivables from customer financing	27	32
Other	– 65	– 53
Other operating changes	– 77	– 56
Outflow of funds from investment activity	– 43	– 85
– of which: pension funding	– 50	–
– of which: inflow of funds from asset disposals	82	16
– of which: hall 11	–	– 19
Free cash flow	– 25	– 43

Heidelberg Excellence

We systematically pursue our target of increasing our corporate value on a long-term basis by means of our 'Heidelberg Excellence' program, which we launched during the current financial year. This program is based on three pillars. We will generate additional sales by offering new products and expanding our business with services, spare parts, and supplies. We will continue our efficiency-boosting and cost reduction measures. In addition to optimizing administrative and sales processes, our focus is primarily on measures to continuously boost efficiency and enhance the streamlining of production and assembly processes, with an important contribution coming from our Heidelberg production system. In the medium term we are aiming at further reducing tied assets through systematic asset management and lowering working capital in terms of sales to 30 percent.

Divisions

We were successful in boosting the incoming orders of the **Press** Division during the second quarter over the previous year, albeit only moderately to € 815 million. We benefited from the trade shows Graph Expo in the US and IGAS in Japan, both of which were held in September. We also profited from the Chinese market, where a considerable volume of incoming orders is being generated following clarification of the customs situation. Demand continued to be strong for our offering in the 'Peak Performance Class': the Speedmaster XL 105. At this year's PIA/GATF InterTech Awards for innovations, we received awards for both this printing press as well as for the Speedmaster SM 52 with Anicolor inking unit. With sales during the second quarter of € 785 million, this division fell short of the previous year's figure – among others, due to the negative foreign currency influences. The result of operating activities during the reporting quarter amounted to € 60 million – € 32 million lower than the previous year's figure. This development was primarily

due not only to the slightly lower volume of sales, but to the positive one-time effect of the sale of Linotype GmbH the previous year as well. The figure for the first half of the year of € 81 million also fell short of the previous year's figure. Due among others to the startup of the new training year, the number of employees increased to 17,326 as of September 30.

The **Postpress** Division enjoyed success during the second quarter, successfully boosting incoming orders to € 109 million and thereby considerably surpassing the previous year's figure, especially due to success in the area of cutters. As already in the first quarter, we were successful in boosting sales over the previous year to € 104 million. For the first half of the financial year sales were thereby 7 percent over the previous year's figure. Following the negative first quarter, during the second quarter this division was able to achieve a break-even result in operating activities. We anticipate a result that is in the black for Postpress during the current financial year. The number of employees rose further, primarily due to the new trainees. As of September 30, 2007 this division had a total of 2,030 employees.

We continue to adhere to our successful strategy in the **Financial Services** Division. During the second quarter, the consistent support of our global and regional financing partners as well as government export credit insurers, together with the devaluation of the US dollar, led to a further decline in receivables from customer financing by € 25 million to € 390 million as of September 30, 2007. Interest income also declined further due to the lower volume of financing. Thanks to the generally stable risk environment and portfolio optimizations, we had a favorable result in the provision for risks during the first half of the year, which made possible a result of operating activities of € 10 million for the quarter alone and € 19 million for the first half-year. This division had a total of 80 employees as of the quarterly reporting date.

Regions

Incoming orders during the first half of the year for the **Europe, Middle East and Africa** region were considerably below the previous year's figures – among others due to the IPEX trade show during the first quarter of the previous year. As in the first quarter, during the second quarter the incoming orders of this region of € 374 million also fell short of the previous year's level. The region's sales reached € 727 million through September 30, 2007, thereby falling just short of the previous year's figure. Whereas sales rose slightly in Germany, in the UK they weakened considerably from the previous year.

INCOMING ORDERS BY REGIONS

2007/2008, Q1 to Q2

2006/2007, Q1 to Q2

Figures in € millions

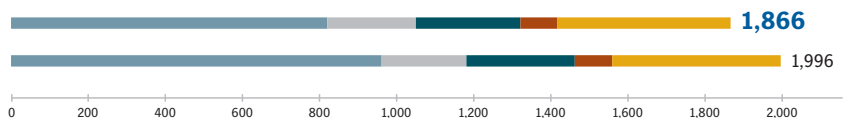

Europe, Middle East and Africa	820	-15 %
Eastern Europe	230	+5 %
North America	271	-4 %
Latin America	96	-1 %
Asia/Pacific	449	+3 %
Heidelberg Group	1,866	-7 %
Europe, Middle East and Africa	374	-11 %
Eastern Europe	103	+8 %
North America	149	-7 %
Latin America	43	-20 %
Asia/Pacific	263	+38 %
Heidelberg Group	932	+1 %

The **Eastern Europe** region continued its upward trend. Incoming orders of € 103 million during the second quarter again exceeded the previous year's figure. Overall, incoming orders in the region were up 5 percent for the first half-year. Sales in the quarter increased by 30 percent over the previous year and 25 percent for the first half of the year! All the larger markets in the region contributed to this development.

The continuing weak US dollar is entirely to blame for the 7 percent fall-off in incoming orders in the **North America** region from the previous year to € 149 million in the second quarter. Adjusted for foreign currency changes, the previous year's level was matched in both the first six months and during the quarter. The Graph Expo trade show, which was held in Chicago during September 9 – 12, was successful. Heidelberg presented its new remote service module eCall for the first time. Entirely foreign-currency-related, this region's sales fell short of the previous year's figures during both the second quarter as well as for the first half of the year.

During the second quarter, the **Latin America** region was unable to completely sustain its strong performance at the beginning of the financial year, with incoming orders of € 43 million remaining below the previous year's level. The two key markets of the region – Brazil and Mexico – were weaker. Sales for the second quarter were not entirely satisfactory. Both incoming orders and sales for the first half of the year remained in the area of the previous year's figures.

NET SALES BY REGIONS				
Figures in € millions				
	Q1 to Q2 prior year	Q1 to Q2 2007/2008	Q2 prior year	Q2 2007/2008
Europe, Middle East and Africa	742	727	402	396
Eastern Europe	166	207	90	117
North America	254	253	142	139
Latin America	83	86	51	46
Asia/Pacific	383	366	224	199
Heidelberg Group	1,628	1,639	909	897

Clarification of the customs situation in the Chinese market has now also had an impact on new orders, with incoming orders of over € 100 million booked during the second quarter reaching the highest level of quarterly orders in over two years! The **Asia/Pacific** region generated incoming orders of € 263 million – substantially above the previous year's figure. In addition to China, Japan also made a contribution to this development. Thanks to the IGAS trade show, which was held in that country at the end of September, despite the existing foreign currency issue, here as well we were successful in considerably boosting incoming orders over the previous year. Sales in the region amounted to € 199 million during the second quarter, falling short of the previous year's figures as in the first half-year as whole. Due to current market conditions, however, we are projecting a strengthening in this region during the course of the financial year.

Research and Development

Our development activity is concentrating on innovative products that we will introduce at drupa 2008, including the entirely new printing press generation Speedmaster XL 145 and XL 162. Together with our offering in the Postpress area, we intend to increase our market share in the packaging printing market with our large format printing presses. We will additionally be supported in our efforts by our packaging workflow system which we will present simultaneously with the market launch of our large format printing presses.

Our R&D work focuses on the typical cost structure of print shops. Every shortening of set-up time or reduction in spoilage that are made possible by the application of our products provides Heidelberg with a selling point. We make it clear to our customers that investing in a Heidelberg printing press is worthwhile if it makes possible a reduction in their overall production costs.

During the first half of the year, research and development costs in the Heidelberg Group amounted to € 111 million – slightly below the previous year's figure. We also anticipate decline in research and development costs from the previous year in the financial year as a whole.

Employees



At our German locations, a total of 204 young people began their apprenticeship at the beginning of the new training year with Heidelberg in September. This was also a factor in the increase in the number of employees to 19,436 people as of the quarterly reporting date – 265 more than the figure for March 31, 2007. Adjusted for the number of apprentices, there were 114 new employees, primarily in production.

Risk and Opportunity Report

In our view, Heidelberg's overall risk has decreased slightly during the course of the financial year. In the 2006/2007 Annual Report, we spotlighted the uncertainty surrounding customs provisions in China as one of our greatest risks. Now that the situation has been clarified, this risk arising from the Chinese market no longer exists. As in the past, we perceive a general risk of increasingly weak market prices due to strong competitive pressures. This could intensify, if exchange rate structures – primarily against the dollar and yen – further develop to our disadvantage. Our business development is decisively determined by the development of the global economy. Following the crisis in the US financial markets, medium-term business prospects nevertheless remain favorable. Our considerable regional diversification reduced our dependency on single markets, since we are less influenced by developments in each of them. Moreover, we have consistently increased our flexibility in recent years through a decline in structural costs reducing susceptibility to fluctuations in customer orders. There are currently no recognizable risks that could threaten the existence of the Heidelberg Group.

Besides risks, there are also opportunities that would favor our business. A change in exchange rates in favor of suppliers from the European region would have a favorable impact on our business development. We would also benefit from the global economy developing more vigorously than has so far been projected.

Future Prospects

Economic research institutes and the IMF currently expect the global economy to develop favorably. The projected growth for calendar year 2007 is approximately 5 percent. We assume that the world economic situation will provide a further impetus to our customers' business. Overall printed volumes will rise moderately, with an above-average, strong pace expected in the emerging markets. We expect the euro to remain rather strong against the Japanese yen and the US dollar – a situation that provides considerable advantages for our Japanese competitors. Nevertheless, this will not endanger our market position either in the sheetfed offset or in the finishing segments.

We are projecting growth in our sales by 10 to 15 percent over the next three years. We expect sales to rise moderately during the current financial year, a so-called pre-drupa year. During the current financial year, we intend to increase the operating result of operating activities by 10 to 15 percent over the adjusted figure for financial year 2006/2007 of € 302 million. A favorable impact is expected on the one hand from the moderately higher sales volume, and on the other hand from our continued, purposeful efficiency-boosting and cost reduction measures in all areas. A negative impact can be expected primarily from less favorable exchange rate structures, greater personnel expenses, and increased burdens in the raw material and energy sector. From today's perspective, the financial result will deteriorate slightly compared to the previous year due in part to changed capital market terms. Benefited, among other things, by the favorable impact of the tax reform and internal optimizations in view of the tax rate, we thereby intend to increase net profit to approximately 5 percent of the sales. As far as free cash flow is concerned, we will be striving for a value of 4 percent of sales during the current financial year as well.

We intend to generate a ROCE of 18 percent in the medium term. With a cost of capital of around 10 percent, we are determined to achieve a value contribution of 8 percent.

Disclaimer

This Quarterly Report contains forward-looking statements based on assumptions and estimations by the Management Board of Heidelberger Druckmaschinen Aktiengesellschaft. Even though the Management Board is of the opinion that these assumptions and estimations are realistic, the actual future development and results may deviate substantially from these forward-looking statements due to various factors, such as changes in the macro-economic situation, in the exchange rates, in the interest rates, and in the print media industry. Heidelberger Druckmaschinen Aktiengesellschaft gives no warranty and does not assume liability for any damages in case the future development and the projected results do not correspond with the forward-looking statements contained in this Quarterly Report.



> THE SECOND QUARTER
IN REVIEW

FINANCIAL YEAR 2007/2008

> THE SECOND QUARTER 2007/2008 IN REVIEW

▼
July 4, 2007
New Training Center

▼
July 26, 2007
Annual General Meeting

July

August

7/2007

8/2007



New Print Media Academy Training Center

July 4, 2007 +++ Opening of the new 'Educ@te Center' in Eppelheim near Heidelberg +++

The 'Educ@te Center', part of the Print Media Academy, offers customers and staff members throughout the world extensive practical and theoretical training activities in offset printing. At present, more than 20 state-of-the-art presses have been installed for training purposes in three halls. Each year, 7,300 participants will be trained in the new training center in some 700 courses, for which Heidelberg employs 140 trainers.



2007 Annual General Meeting

July 26, 2007 +++ All items on the agenda approved +++

This year, around 1,500 shareholders participated in the Annual General Meeting of Heidelberger Druckmaschinen Aktiengesellschaft, representing approximately 63 percent of the share capital. Among other things, the shareholders approved the appropriation of retained earnings and the associated distribution of a dividend of € 0.95 per participating share. Furthermore, the proposal to appoint Dr. Siegfried Jaschinski to the Supervisory Board was approved; he succeeds Prof. Dr. Clemens Börsig on the Heidelberg Supervisory Board.

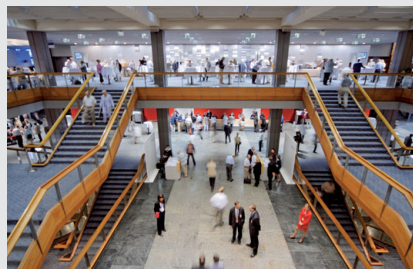

Second Share Buyback Program Concluded

September 4, 2007 +++ A further 5 percent of the capital stock repurchased +++

The second share buyback program of Heidelberg, which had begun in November 2006, was concluded in September. A total of 4,152,535 shares amounting to approximately € 139 million were bought back.

2007 / 08

September 4, 2007 Share Buyback Program Concluded
September 9 – 12, 2007 eCall at Graph Expo

September 5, 2007
Award-winning Annual Report

September 15, 2007
Official Inauguration of Assembly Hall 11

September

9/2007

Award-winning Annual Report

September 5, 2007 +++ Again first place among MDAX firms +++

For the third consecutive year, 'manager magazin' awarded Heidelberg's annual report first place among MDAX firms. All in all, Heidelberg came in first in this segment for the sixth time. In the overall ranking, the Company was awarded second place, as in the previous year. Heidelberg's CFO, Dirk Kaliebe, who accepted the award, rated the success a further confirmation of the continuity and quality of the Company's financial reporting.



eCall at Graph Expo 2007

September 9 – 12, 2007 +++ Heidelberg presents new Remote Service Module +++

Among other things, Heidelberg unveiled its new web-based Remote Service eCall at Graph Expo 2007. Operators of presses equipped with this module can – with the touch of a button – automatically send an error message to the Heidelberg service organization. Based on this information, the Heidelberg team of experts can develop a solution proposal.



Official Inauguration of the Assembly Hall for a New Generation of Printing Presses

September 15, 2007 +++ Inauguration at the 50th anniversary of the Wiesloch-Walldorf plant +++

Following a construction phase of around 14 months, the new assembly hall 11 at the Wiesloch-Walldorf plant was officially opened in September. The investment volume totaled € 45 million. In this hall, Heidelberg will assemble a completely new generation of very large format printing presses, the Speedmaster XL 145 and Speedmaster XL 162. With these new format classes, Heidelberg intends to expand its existing product portfolio. The Company is looking to tap into new markets, and reinforce its commitment in packaging printing.

The new hall represents a kind of 'anniversary gift' for the site. At the same time as the hall was officially opened, Heidelberg was also celebrating the 50th anniversary of the Wiesloch-Walldorf site, the world's largest printing press factory.

> CONSOLIDATED INTERIM FINANCIAL STATEMENTS

for the period April 1, 2007 to September 30, 2007

20	Interim income statement – April 1, 2007 to September 30, 2007
21	Interim income statement – July 1, 2007 to September 30, 2007
22	Interim income statement – Quarterly overview
23	Interim balance sheet
25	Cash flow statement – April 1, 2007 to September 30, 2007
26	Cash flow statement – Quarterly overview
27	Statement of recognized income and expense
27	Development of shareholders' equity
28	Segment information
30	Notes

**Consolidated interim
income statement
April 1, 2007 to
September 30, 2007**

> INTERIM INCOME STATEMENT

Figures in € thousands			
	Note	1-Apr-2006 to 30-Sep-2006	1-Apr-2007 to 30-Sep-2007
Net sales		1,627,717	1,639,250
Change in inventories		83,175	126,516
Other own work capitalized		25,532	37,219
Total operating performance		1,736,424	1,802,985
Other operating income	3	119,454	88,253
Cost of materials	4	763,175	802,283
Personnel expenses		562,929	592,953
Depreciation and amortization		64,804	59,401
Other operating expenses	5	346,985	340,533
Result of operating activities		117,985	96,068
Result from the equity valuation		- 20	-
Financial income	6	14,678	9,587
Financial expenses	7	38,934	40,980
Financial result		- 24,276	- 31,393
Income before taxes		93,709	64,675
Taxes on income		26,121	20,313
Consolidated net profit		67,588	44,362
Minority interests		- 171	- 227
Consolidated net profit – Heidelberg portion		67,759	44,589
Undiluted earnings per share according to IAS 33 (in € per share)	8	0.83	0.57
Diluted earnings per share according to IAS 33 (in € per share)	8	0.81	-

**Consolidated interim
income statement
July 1, 2007 to
September 30, 2007**

> INTERIM INCOME STATEMENT

	1-Jul-2006 to 30-Sep-2006	1-Jul-2007 to 30-Sep-2007
Figures in € thousands		
Net sales	908,762	897,032
Change in inventories	- 6,154	13,398
Other own work capitalized	11,437	14,585
Total operating performance	914,045	925,015
Other operating income	72,480	48,615
Cost of materials	397,741	408,929
Personnel expenses	278,853	291,627
Depreciation and amortization	33,685	29,843
Other operating expenses	173,891	173,149
Result of operating activities	102,355	70,082
Result from the equity valuation	180	-
Financial income	7,208	5,721
Financial expenses	22,083	23,321
Financial result	- 14,695	- 17,600
Income before taxes	87,660	52,482
Taxes on income	24,662	16,030
Consolidated net profit	62,998	36,452
Minority interests	- 77	- 81
Consolidated net profit – Heidelberg portion	63,075	36,533
Undiluted earnings per share according to IAS 33 (in € per share)	0.77	0.47

**Consolidated interim
income statement –
Quarterly overview**

> INTERIM INCOME STATEMENT

Figures in € thousands	1-Apr-2007 to 30-Jun-2007	1-Jul-2007 to 30-Sep-2007	1-Apr-2007 to 30-Sep-2007
Net sales	742,218	897,032	1,639,250
Change in inventories	113,118	13,398	126,516
Other own work capitalized	22,634	14,585	37,219
Total operating performance	877,970	925,015	1,802,985
Other operating income	39,638	48,615	88,253
Cost of materials	393,354	408,929	802,283
Personnel expenses	301,326	291,627	592,953
Depreciation and amortization	29,558	29,843	59,401
Other operating expenses	167,384	173,149	340,533
Result of operating activities	25,986	70,082	96,068
Result from the equity valuation	–	–	–
Financial income	3,866	5,721	9,587
Financial expenses	17,659	23,321	40,980
Financial result	– 13,793	– 17,600	– 31,393
Income before taxes	12,193	52,482	64,675
Taxes on income	4,283	16,030	20,313
Consolidated net profit	7,910	36,452	44,362
Minority interests	– 146	– 81	– 227
Consolidated net profit – Heidelberg portion	8,056	36,533	44,589
Undiluted earnings per share according to IAS 33 (in € per share)	0.10	0.47	0.57

**Consolidated interim
balance sheet as of
September 30, 2007**

>>>

> **ASSETS**

Figures in € thousands

	Note	31-Mar-2007	30-Sep-2007
Non-current assets			
Intangible assets	9	261,024	270,372
Tangible assets	9	528,241	540,672
Investment property	9	21,546	19,981
Financial assets	10	46,675	48,862
Receivables from customer financing	11	319,880	268,684
Other receivables and other assets	11	88,052	155,616
Income tax assets		74,098	66,607
Deferred tax assets		72,034	69,927
		<u>1,411,550</u>	<u>1,440,721</u>
Current assets			
Inventories	12	900,701	1,047,472
Receivables from customer financing	11	111,523	121,609
Trade receivables	11	704,538	580,556
Other receivables and other assets	11	122,096	164,631
Income tax assets		9,424	23,349
Marketable securities		2,908	683
Cash and cash equivalents		76,339	84,014
		<u>1,927,529</u>	<u>2,022,314</u>
Assets held for sale			
		–	585
Total assets		<u>3,339,079</u>	<u>3,463,620</u>

> EQUITY AND LIABILITIES

Figures in € thousands

	Note	31-Mar-2007	30-Sep-2007
Shareholders' equity	13		
Subscribed capital		203,080	198,643
Capital and revenue reserves		733,272	911,453
Consolidated net profit – Heidelberg portion		262,993	44,589
		1,199,345	1,154,685
Minority interests		2,326	–
		1,201,671	1,154,685
Non-current liabilities			
Provisions for pensions and similar obligations	14	132,940	116,706
Other provisions	15	374,035	360,695
Financial liabilities	16	421,504	421,158
Other liabilities	17	109,370	105,449
Deferred tax liabilities		85,710	111,366
		1,123,559	1,115,374
Current liabilities			
Other provisions ¹⁾	15	328,668	295,243
Financial liabilities	16	121,882	310,101
Trade payables ¹⁾		249,753	228,222
Income tax liabilities		8,185	3,713
Other liabilities ¹⁾	17	305,361	356,282
		1,013,849	1,193,561
Total equity and liabilities		3,339,079	3,463,620

¹⁾ Previous year's figures were adjusted (see Note 1)

> CONSOLIDATED CASH FLOW STATEMENT

Figures in € thousands	1-Apr-2006 to 30-Sep-2006	1-Apr-2007 to 30-Sep-2007
Consolidated net profit	67,588	44,362
Depreciation and amortization ¹⁾	64,804	59,401
Change in pension provisions	- 5,526	- 5,134
Change in deferred tax assets / deferred tax liabilities / tax provisions	14,882	757
Result from the equity valuation	20	-
Result from disposals	- 47,574	- 2,044
Cash flow	94,194	97,342
Change in inventories	- 124,011	- 156,878
Change in customer financing	26,837	31,505
Change in trade receivables / trade payables ²⁾	72,060	91,416
Change in other provisions ²⁾	- 26,080	- 39,671
Change in other balance sheet items ²⁾	- 25,601	17,916
Other operating changes	- 76,795	- 55,712
Inflow of funds from operating activities	17,399	41,630
Intangible assets / tangible assets / investment property		
Investments	- 65,857	- 95,650
Proceeds from disposals	30,021	15,955
Financial assets		
Investments	- 8,627	- 4,990
Proceeds from disposals	51,710	178
Pension funding	- 50,000	-
Outflow of funds from investment activity	- 42,753	- 84,507
Free cash flow	- 25,354	- 42,877
Treasury stock	- 52,055	- 57,781
Dividend payment	- 53,275	- 74,801
Change in financial liabilities	142,355	182,124
Inflow of funds from financing activity	37,025	49,542
Net change in cash and cash equivalents	11,671	6,665
Cash and cash equivalents at the beginning of the quarter	79,679	79,247
Currency adjustments	- 1,365	- 1,215
Net change in cash and cash equivalents	11,671	6,665
Cash and cash equivalents at the end of the quarter	89,985	84,697

¹⁾ Relates to intangible assets, tangible assets, investment property, and financial assets

²⁾ Previous year's figures were adjusted (see Note 1)

> CONSOLIDATED CASH FLOW STATEMENT – QUARTERLY OVERVIEW

Figures in € thousands			
	1-Apr-2007 to 30-Jun-2007	1-Jul-2007 to 30-Sep-2007	1-Apr-2007 to 30-Sep-2007
Consolidated net profit	7,910	36,452	44,362
Depreciation and amortization ¹⁾	29,558	29,843	59,401
Change in pension provisions	-2,268	-2,866	-5,134
Change in deferred tax assets/ deferred tax liabilities / tax provisions	-7,327	8,084	757
Result from the equity valuation	-	-	-
Result from disposals	461	-2,505	-2,044
Cash flow	28,334	69,008	97,342
Change in inventories	-137,216	-19,662	-156,878
Change in customer financing	16,120	15,385	31,505
Change in trade receivables / trade payables	100,210	-8,794	91,416
Change in other provisions	-26,442	-13,229	-39,671
Change in other balance sheet items	-11,521	29,437	17,916
Other operating changes	-58,849	3,137	-55,712
Outflow/inflow of funds from operating activities	-30,515	72,145	41,630
Intangible assets / tangible assets / investment property			
Investments	-52,415	-43,235	-95,650
Proceeds from disposals	4,797	11,158	15,955
Financial assets			
Investments	-2,383	-2,607	-4,990
Proceeds from disposals	-	178	178
Pension funding	-	-	-
Outflow of funds from investment activity	-50,001	-34,506	-84,507
Free cash flow	-80,516	37,639	-42,877
Treasury stock	-17,471	-40,310	-57,781
Dividend payment	-	-74,801	-74,801
Change in financial liabilities	94,128	87,996	182,124
Inflow/outflow of funds from financing activity	76,657	-27,115	49,542
Net change in cash and cash equivalents	-3,859	10,524	6,665
Cash and cash equivalents at the beginning of the quarter	79,247	75,505	79,247
Currency adjustments	117	-1,332	-1,215
Net change in cash and cash equivalents	-3,859	10,524	6,665
Cash and cash equivalents at the end of the quarter	75,505	84,697	84,697

¹⁾ Relates to intangible assets, tangible assets, investment property, and financial assets

> STATEMENT OF RECOGNIZED INCOME AND EXPENSE

Figures in € thousands		
	1-Apr-2006 to 30-Sep-2006	1-Apr-2007 to 30-Sep-2007
Consolidated net profit	67,588	44,362
Pension obligations ¹⁾	13,214	59,837
Foreign currency translation	- 27,023	- 27,768
Financial assets	- 203	- 88
Cash flow hedges	502	10,770
Total recognized income and expense without effect on the income statement	- 13,510	42,751
Total recognized income and expense	54,078	87,113
- of which: Heidelberg Group	54,292	87,391
- of which: minority interests	- 214	- 278

¹⁾ Changes in actuarial gains and losses and in asset ceiling due to IAS 19.58 b)

> DEVELOPMENT OF SHAREHOLDERS' EQUITY

Figures in € thousands		
	2006	2007
Shareholders' equity as of April 1	1,137,712	1,201,671
Total recognized income and expense without effect on the income statement	- 13,510	42,751
Consolidated net profit	67,588	44,362
Total recognized income and expense	54,078	87,113
Dividend payment	- 53,275	- 74,801
Purchase of treasury stock	- 52,055	- 57,781
Consolidations/other changes	4,176	- 1,517
Shareholders' equity as of September 30	1,090,636	1,154,685

Consolidated segment information April 1, 2007 to September 30, 2007

> SEGMENT INFORMATION BY DIVISION

Figures in € thousands					
		Press		Postpress	
	1-Apr-2006 to 30-Sep-2006	1-Apr-2007 to 30-Sep-2007	1-Apr-2006 to 30-Sep-2006	1-Apr-2007 to 30-Sep-2007	
External sales	1,422,471	1,424,057	185,944	198,975	
Depreciation ¹⁾	61,908	56,064	2,859	3,130	
Non-cash expenses	173,455	176,891	12,409	16,047	
Research and development costs	104,461	98,369	11,655	12,695	
Result of operating activities (segment result)	95,619	81,276	539	-3,861	
Result from the equity valuation	-20	-	-	-	
Investments	63,771	92,218	1,975	3,429	
Segment assets ²⁾	2,336,401	2,508,089	268,962	266,077	
Segment debt ²⁾	1,071,853	1,033,745	94,227	101,869	
Number of employees ²⁾	17,100	17,326	1,988	2,030	

> SEGMENT INFORMATION BY REGION

Figures in € thousands					
	Europe, Middle East and Africa		Eastern Europe		
	1-Apr-2006 to 30-Sep-2006	1-Apr-2007 to 30-Sep-2007	1-Apr-2006 to 30-Sep-2006	1-Apr-2007 to 30-Sep-2007	
External sales by customer location	742,115	727,405	165,653	207,072	
Investments	61,157	86,549	2,312	604	
Segment assets ²⁾	1,940,218	2,127,339	165,116	171,003	

For additional explanations see Note 19

¹⁾ No impairments occurred during the reporting period (previous year: € 1,966 thousand)

²⁾ Previous year's figures refer to March 31, 2007

Financial Services		Heidelberg Group	
1-Apr-2006 to 30-Sep-2006	1-Apr-2007 to 30-Sep-2007	1-Apr-2006 to 30-Sep-2006	1-Apr-2007 to 30-Sep-2007
19,302	16,218	1,627,717	1,639,250
37	207	64,804	59,401
8,969	9,949	194,833	202,887
–	–	116,116	111,064
21,827	18,653	117,985	96,068
–	–	–20	–
111	3	65,857	95,650
437,364	399,717	3,042,727	3,173,883
99,331	112,846	1,265,411	1,248,460
83	80	19,171	19,436

North America		Latin America		Asia/Pacific		Heidelberg Group	
1-Apr-2006 to 30-Sep-2006	1-Apr-2007 to 30-Sep-2007	1-Apr-2006 to 30-Sep-2006	1-Apr-2007 to 30-Sep-2007	1-Apr-2006 to 30-Sep-2006	1-Apr-2007 to 30-Sep-2007	1-Apr-2006 to 30-Sep-2006	1-Apr-2007 to 30-Sep-2007
254,051	253,145	82,689	85,963	383,209	365,665	1,627,717	1,639,250
984	6,900	511	485	893	1,112	65,857	95,650
335,482	269,289	181,156	175,090	420,755	431,162	3,042,727	3,173,883

Notes

1 Accounting and valuation policies

The consolidated interim financial report as of September 30, 2007 was prepared in accordance with the International Financial Reporting Standards (IFRS) which became effective and binding at that time. The IFRS comprise the IFRS newly released by the International Accounting Standards Board (IASB), as well as the International Accounting Standards (IAS), and the interpretations of the International Financial Reporting Interpretations Committee (IFRIC) and of the Standing Interpretations Committee (SIC).

The consolidated interim financial report was strictly based on the same accounting and valuation policies as the consolidated Annual Report for the financial year 2006/2007, and complies with the provisions of IAS 34 (Interim financial reporting). In accordance with IAS 37 (Provisions, contingent liabilities, and contingent assets), accrued liabilities for outstanding balances and accrued liabilities from the human resources area are shown in trade payables or in other liabilities. The previous year's figures were adjusted accordingly.

The standards and interpretations becoming initially effective and binding beginning in financial year 2007/2008 had no significant influence on the interim statement. The initial application of IFRS 7 and the amendments to IAS 1 will result in an extension of the Notes to the Financial Statements. The impact of standards already released but not yet applicable are currently being analyzed.

Revenues that are received seasonally, cyclically, or occasionally are not anticipated or deferred in the consolidated interim financial report. Costs incurred unevenly during the financial year were deferred if deferral would be appropriate at the end of the financial year.

On July 6, 2007 the second chamber of the German Parliament (Bundesrat) approved the business tax reform 2008. Beginning in 2008, the new code will result in far-reaching changes affecting the determination of taxable profit and income as well as income tax rates. For German companies, the business tax reform provides for a reduction in the income tax rate from 37.37 percent to 28.14 percent.

The interim financial statements have neither been audited according to § 317 HGB (German Commercial Code) nor reviewed by the auditor.

2 Scope of the consolidation

Apart from Heidelberger Druckmaschinen Aktiengesellschaft, the consolidated interim financial statements include a total of 70 (March 31, 2007: 70) domestic and foreign companies in which Heidelberger Druckmaschinen

Aktiengesellschaft is in a position to exercise control as defined by IAS 27. Of these companies, 63 (March 31, 2007: 63) are located outside Germany. Shares in subsidiaries that are of minor significance are not included.

The scope of the consolidation remained unchanged compared with March 31, 2007.

3 Other operating income

	1-Apr-2006 to 30-Sep-2006	1-Apr-2007 to 30-Sep-2007
Reversal of other provisions/accrued liabilities	21,980	30,479
Income from written-off receivables	10,097	10,529
Income from operating facilities	9,834	9,392
Hedging transactions/foreign-exchange profit	7,944	8,438
Income from disposals of intangible assets, tangible assets, and investment property	7,487	2,621
Income from the deconsolidation of companies	37,594	–
Other income	24,518	26,794
	<u>119,454</u>	<u>88,253</u>

Income from hedging transactions/foreign-exchange profits is offset by expenses from hedging transactions/foreign-exchange losses that are shown in other operating expenses (Note 5).

4 Cost of materials

	1-Apr-2006 to 30-Sep-2006	1-Apr-2007 to 30-Sep-2007
Expenses for raw materials, consumables, and supplies, as well as for goods purchased	649,067	693,509
Costs of purchased services	112,074	107,725
Interest expenses of Financial Services	2,034	1,049
	<u>763,175</u>	<u>802,283</u>

Proportionate interest expenses accrued in connection with the Financial Services Division are shown in the cost of materials. Interest income from customer financing totaling € 16,218 thousand (previous year: € 19,302 thousand) is included in net sales.

5 Other operating expenses

	1-Apr-2006 to 30-Sep-2006	1-Apr-2007 to 30-Sep-2007
Other deliveries and services not included in the cost of materials	58,711	62,158
Special direct sales expenses including freight charges	64,011	61,789
Travel expenses	28,625	31,985
Rent and leases (excluding car fleet)	28,938	29,340
Costs of information technology	27,208	28,417
Legal, consulting, and audit fees	9,280	12,129
Provisions for doubtful accounts and other assets	17,429	11,090
Costs of car fleet	9,632	10,058
Insurance expense	8,829	9,576
Additions to provisions (relates to several expense accounts)	12,468	8,634
Expenses from operating facilities	6,267	7,081
Costs of mail and payment transactions	6,418	6,308
Other research and development costs	10,100	5,386
Public-sector fees and other taxes	4,801	4,759
Hedging transactions/exchange rate losses	6,027	4,129
License fees	1,966	2,900
Office supplies, newspapers, technical literature	1,880	1,996
Losses from disposals of intangible assets and tangible assets	208	724
Other overhead costs	44,187	42,074
	<u>346,985</u>	<u>340,533</u>

Expenses from hedging transactions/foreign-exchange losses are offset by income from hedging transactions/foreign-exchange profits that are shown in other operating income (Note 3).

6 Financial income

	1-Apr-2006 to 30-Sep-2006	1-Apr-2007 to 30-Sep-2007
Interest and similar income	10,215	7,104
Income from financial assets/loans/marketable securities	4,463	2,483
	<u>14,678</u>	<u>9,587</u>

7 Financial expenses

	1-Apr-2006 to 30-Sep-2006	1-Apr-2007 to 30-Sep-2007
Interest and similar expenses	34,319	35,889
Expenses from financial assets/loans/marketable securities	4,615	5,091
	<u>38,934</u>	<u>40,980</u>

8 Earnings per share

Earnings per share are calculated by dividing the net profit to which the shareholders of Heidelberg are entitled by the weighted number of shares outstanding during the period (first six months 2007/2008: 78,632,655 no-par shares). The weighted number of outstanding shares was influenced by the purchase of treasury stock in the first six months of the financial year. As at September 30, 2007 the treasury stock comprised 2,133,113 shares.

9 Intangible assets, tangible assets, and investment property

	Intangible assets	Tangible assets	Investment property
Acquisition or manufacturing cost 31-Mar-2007	437,393	2,012,296	60,926
Acquisition or manufacturing cost 30-Sep-2007	<u>459,260</u>	<u>2,032,754</u>	<u>58,347</u>
Accumulated depreciation 31-Mar-2007	176,369	1,484,055	39,380
Accumulated depreciation 30-Sep-2007	<u>188,888</u>	<u>1,492,082</u>	<u>38,366</u>
Book values 31-Mar-2007	261,024	528,241	21,546
Book values 30-Sep-2007	<u>270,372</u>	<u>540,672</u>	<u>19,981</u>

10 Financial assets

Financial assets primarily include shares in affiliated companies totaling € 25,031 thousand (March 31, 2007: € 22,371 thousand) as well as other investments totaling € 15,511 thousand (March 31, 2007: € 16,236 thousand), and securities totaling € 8,320 thousand (March 31, 2007: € 8,068 thousand).

11 Receivables and other assets

	31-Mar-2007			30-Sep-2007		
	Current	Non-current	Total	Current	Non-current	Total
Receivables from customer financing	111,523	319,880	431,403	121,609	268,684	390,293
Trade receivables	704,538	–	704,538	580,556	–	580,556
Other receivables and other assets						
Other tax refund claims	21,717	1,430	23,147	22,989	–	22,989
Loans	248	6,008	6,256	641	7,305	7,946
Derivative financial instruments	23,018	6,462	29,480	37,228	10,643	47,871
Deferred interest payments	1,795	–	1,795	1,712	–	1,712
Prepaid expenses	12,389	1,054	13,443	29,490	–	29,490
Other assets	62,929	73,098	136,027	72,571	137,668	210,239
	122,096	88,052	210,148	164,631	155,616	320,247

12 Inventories

	31-Mar-2007	30-Sep-2007
Raw materials, consumables, and supplies	130,679	137,318
Work and services in process	350,720	385,439
Manufactured products and merchandise	406,977	513,446
Prepayments	12,325	11,269
	900,701	1,047,472

13 Shareholders' equity

At the Annual General Meeting on July 20, 2006, the Management Board of Heidelberger Druckmaschinen Aktiengesellschaft was authorized to acquire the Company's own shares in an amount of up to 10 percent of the capital stock available at that time or – should this amount be lower – of the capital stock available at the time of the authorization's implementation for any acceptable purpose up to January 19, 2008. The Management Board of Heidelberger Druckmaschinen Aktiengesellschaft made use of this authorization on October 31, 2006 and decided to acquire the Company's own shares in an amount of up to 5 percent of the capital stock (up to 4,152,535 shares) during the period November 7, 2006 through January 19, 2008 at the latest. The repurchased shares may only be utilized for the reduction of the Company's capital stock, for employee share participation programs, or for other forms of share distribution to the employees of the Company or of a subsidiary or may be offered for purchase to individuals who are or were employed by the Company or affiliated enterprises. This share buyback program was concluded on September 4, 2007.

By March 31, 2007 a total of 2,419,422 shares were repurchased at a cost of € 81,023 thousand. As of September 30, 2007 400,000 shares thereof (acquisition cost: € 13,258 thousand) were still held as treasury stock – the same as at March 31, 2007. Furthermore, during the period April 1, 2007 until September 30, 2007, an additional 1,733,113 shares were repurchased at an acquisition cost of € 57,781 thousand and were also held as treasury stock on September 30, 2007.

The authorization granted by the Annual General Meeting on July 20, 2006 would have expired on January 19, 2008. To ensure seamless authorization, this authorization was canceled in accordance with a decision by the Annual General Meeting of July 26, 2007 and replaced by a new authorization of the Management Board to acquire the Company's own shares in an amount of up to the lower of 10 percent of either the capital stock available on July 26, 2007 or of the capital stock at the time of the exercise of the authorization for any permissible purpose up to January 25, 2009.

14 Provisions for pensions and similar obligations

We maintain benefit programs for the majority of employees for the period following their retirement – either through the direct program or one financed by payments of premiums to private institutions. The level of benefit payments depends on the conditions in particular countries. The amounts are generally based on the term of employment and the salary of the employees. The liabilities include both those arising from current

pensions as well as vested pension rights for pensions payable in the future. The pension payments expected following the beginning of benefit payments are apportioned over the employee's overall period of employment. After deduction of deferred taxes, the actuarial gains and losses are offset to shareholders' equity without effect on the income statement. As of September 30, 2007, a discount rate of 5.5 percent (March 31, 2007: 4.75 percent) was applied for domestic companies.

15 Other provisions

	31-Mar-2007			30-Sep-2007		
	Current	Non-current	Total	Current	Non-current	Total
Tax provisions	19,444	250,450	269,894	27,167	243,505	270,672
Other provisions						
Liabilities arising from human resources ¹⁾	92,700	53,286	145,986	79,613	48,287	127,900
Liabilities arising from sales and service activities	161,879	30,567	192,446	148,043	27,029	175,072
Other ¹⁾	54,645	39,732	94,377	40,420	41,874	82,294
	<u>309,224</u>	<u>123,585</u>	<u>432,809</u>	<u>268,076</u>	<u>117,190</u>	<u>385,266</u>
	<u>328,668</u>	<u>374,035</u>	<u>702,703</u>	<u>295,243</u>	<u>360,695</u>	<u>655,938</u>

¹⁾ Previous year's figures were adjusted (see Note 1)

16 Financial liabilities

	31-Mar-2007			30-Sep-2007		
	Current	Non-current	Total	Current	Non-current	Total
Convertible bond	–	286,533	286,533	–	290,794	290,794
Borrower's note loans	7,279	130,500	137,779	7,281	127,000	134,281
To banks	84,460	–	84,460	275,425	–	275,425
From finance lease contracts	6,929	4,471	11,400	5,982	3,364	9,346
Other	23,214	–	23,214	21,413	–	21,413
	<u>121,882</u>	<u>421,504</u>	<u>543,386</u>	<u>310,101</u>	<u>421,158</u>	<u>731,259</u>

17 Other liabilities

	31-Mar-2007			30-Sep-2007		
	Current	Non-current	Total	Current	Non-current	Total
Advance payments received on orders	79,653	–	79,653	108,467	–	108,467
Accrued liabilities from human resources ¹⁾	81,760	–	81,760	82,988	–	82,988
From derivative financial instruments	6,505	861	7,366	20,618	76	20,694
From other taxes	39,592	–	39,592	32,862	–	32,862
Relating to social security	9,254	–	9,254	6,944	2,928	9,872
Deferred income	34,561	35,587	70,148	46,401	30,468	76,869
Other	54,036	72,922	126,958	58,002	71,977	129,979
	<u>305,361</u>	<u>109,370</u>	<u>414,731</u>	<u>356,282</u>	<u>105,449</u>	<u>461,731</u>

¹⁾ Previous year's figures were adjusted (see Note 1)

18 Contingent liabilities and other financial liabilities

As of September 30, 2007 contingent liabilities for warranties and guarantees totaled € 197,506 thousand (March 31, 2007: € 218,686 thousand); they primarily comprise guarantees provided for the liabilities of third parties in connection with non-current customer financing, which in turn largely correspond with recourse rights on the delivered assets.

Other financial liabilities are broken down as follows:

	31-Mar-2007			30-Sep-2007		
	Current	Non-current	Total	Current	Non-current	Total
Lease obligations	58,454	362,611	421,065	55,891	350,268	406,159
Investments	71,593	2,937	74,530	75,592	2,980	78,572
	<u>130,047</u>	<u>365,548</u>	<u>495,595</u>	<u>131,483</u>	<u>353,248</u>	<u>484,731</u>

19 Information concerning segment reporting

The segment information is based on the **'risk and reward approach'**. Inter-segmental sales are of minor financial significance and may therefore be ignored.

Non-cash expenses comprise the following:

	1-Apr-2006 to 30-Sep-2006	1-Apr-2007 to 30-Sep-2007
Provisions for doubtful accounts and other assets	17,429	11,090
Additions to provisions and accrued liabilities	177,404	191,797
	<u>194,833</u>	<u>202,887</u>

Research and development costs result from research and development costs incurred in the reporting period, however, excluding depreciation on the development costs for the reporting period.

Investments comprise investments in intangible assets, tangible assets, as well as investment property.

Segment assets and **segment debt** result from gross assets or gross debt as follows:

	31-Mar-2007	30-Sep-2007
Assets per balance sheet	3,339,079	3,463,620
– financial assets	– 46,675	– 48,862
– marketable securities	– 2,908	– 683
– finance receivables	– 68,066	– 57,320
– deferred tax assets	– 72,034	– 69,927
– tax refund claims	– 106,669	– 112,945
Segment assets	<u>3,042,727</u>	<u>3,173,883</u>

	31-Mar-2007	30-Sep-2007
Liabilities per balance sheet	2,137,408	2,308,935
– tax provisions	– 269,894	– 270,672
– tax obligations	– 47,777	– 36,575
– financial obligations	– 468,616	– 641,862
– deferred tax liabilities	– 85,710	– 111,366
Segment liabilities	<u>1,265,411</u>	<u>1,248,460</u>

Finance receivables comprise finance receivables against affiliated companies and other financial assets.

Financial liabilities comprise the items specified in Note 16, with the exception of financial liabilities associated with customer financing.

The **number of employees** was recorded as of September 30, 2007 compared with March 31, 2007.

**20 Supervisory Board/
Management Board**

The members of the Supervisory Board and the Management Board are listed on page 41.

**21 Transactions
with related parties**

As described in our notes to the consolidated financial statements as of March 31, 2007 under Note 38, Heidelberger Druckmaschinen Aktiengesellschaft and its subsidiaries undertake business dealings with numerous companies in the ordinary course of business. This also includes associated companies, which are regarded as related companies of the Heidelberg Group. All business dealings were concluded at terms that are customary in the market and which as a matter of principle do not differ from delivery and service relationships with other companies.

Also unchanged compared to the wording in Note 38 in the Notes to the Consolidated Financial Statements as of March 31, 2007, no significant transactions were undertaken by the Heidelberg Group with closely related individuals.

**22 Information on events
after the reporting date**

No significant events occurred after the reporting date.

Responsibility Statement by the Management Board

To the best of our knowledge, and in accordance with the applicable reporting principles for interim financial reporting, the interim consolidated financial statements give a true and fair view of the assets, liabilities, financial position, and profit or loss of the Group, and the interim management report of the Group includes a fair review of the development and performance of the business and the position of the Group, together with a description of the principal opportunities and risks associated with the expected development of the Group for the remaining months of the financial year.

Heidelberg, November 6, 2007

Heidelberger Druckmaschinen Aktiengesellschaft
The Management Board



Bernhard Schreier



Dirk Kaliebe



Dr. Jürgen Rautert

Supervisory Board

Dr. Mark Wössner

Chairman of the
Supervisory Board

Rainer Wagner*

Deputy Chairman
of the Supervisory Board

Martin Blessing

Wolfgang Flörchinger*

Martin Gauß*

Mirko Geiger*

Gunther Heller*

Dr. Jürgen Heraeus

Jörg Hofmann*

Dr. Siegfried Jaschinski

– since April 3, 2007 –

Robert J. Koehler

Uwe Lüders

Dr. Gerhard Rupprecht

Beate Schmitt*

Dr. Klaus Sturany

Peter Sudadse*

Committees of the Supervisory Board

Management Committee

Dr. Mark Wössner
Rainer Wagner
Martin Blessing
Martin Gauß
Mirko Geiger
Dr. Gerhard Rupprecht

Mediation Committee under Article 27 Subsection 3 of the Codetermination Act

Dr. Mark Wössner
Rainer Wagner
Martin Blessing
Wolfgang Flörchinger

Committee on Arranging Personnel Matters of the Management Board

Dr. Mark Wössner
Rainer Wagner
Dr. Gerhard Rupprecht

Audit Committee

Dr. Klaus Sturany
Dr. Jürgen Heraeus
– since April 26, 2007 –
Mirko Geiger
Rainer Wagner

Management Board

Bernhard Schreier

Chairman of the
Management Board

Dirk Kaliebe

Dr. Jürgen Rautert

* Employee Representative

Financial Calendar 2007/2008

February 5, 2008	Publication of 3rd Quarter Figures 2007/2008
May 7, 2008	Publication of Preliminary Figures 2007/2008
June 10, 2008	Press Conference, Annual Analysts' and Investors' Conference
July 18, 2008	Annual General Meeting
August 5, 2008	Publication of 1st Quarter Figures 2008/2009
November 6, 2008	Publication of Half-Year Figures 2008/2009

Subject to change

This report was published on November 6, 2007.

Copyright © 2007

Heidelberger Druckmaschinen
Aktiengesellschaft
Kurfuersten-Anlage 52 – 60
69115 Heidelberg
Germany
www.heidelberg.com
investorrelations@heidelberg.com

This Interim Financial Report is a translation of the official German Interim Financial Report of Heidelberger Druckmaschinen Aktiengesellschaft. The Company disclaims responsibility for any misunderstanding or misinterpretation due to this translation.

Photo credits: Archive Heidelberger Druckmaschinen AG.

Produced on Heidelberg machines using Heidelberg technology.

All rights and technical changes reserved.

Printed in Germany.

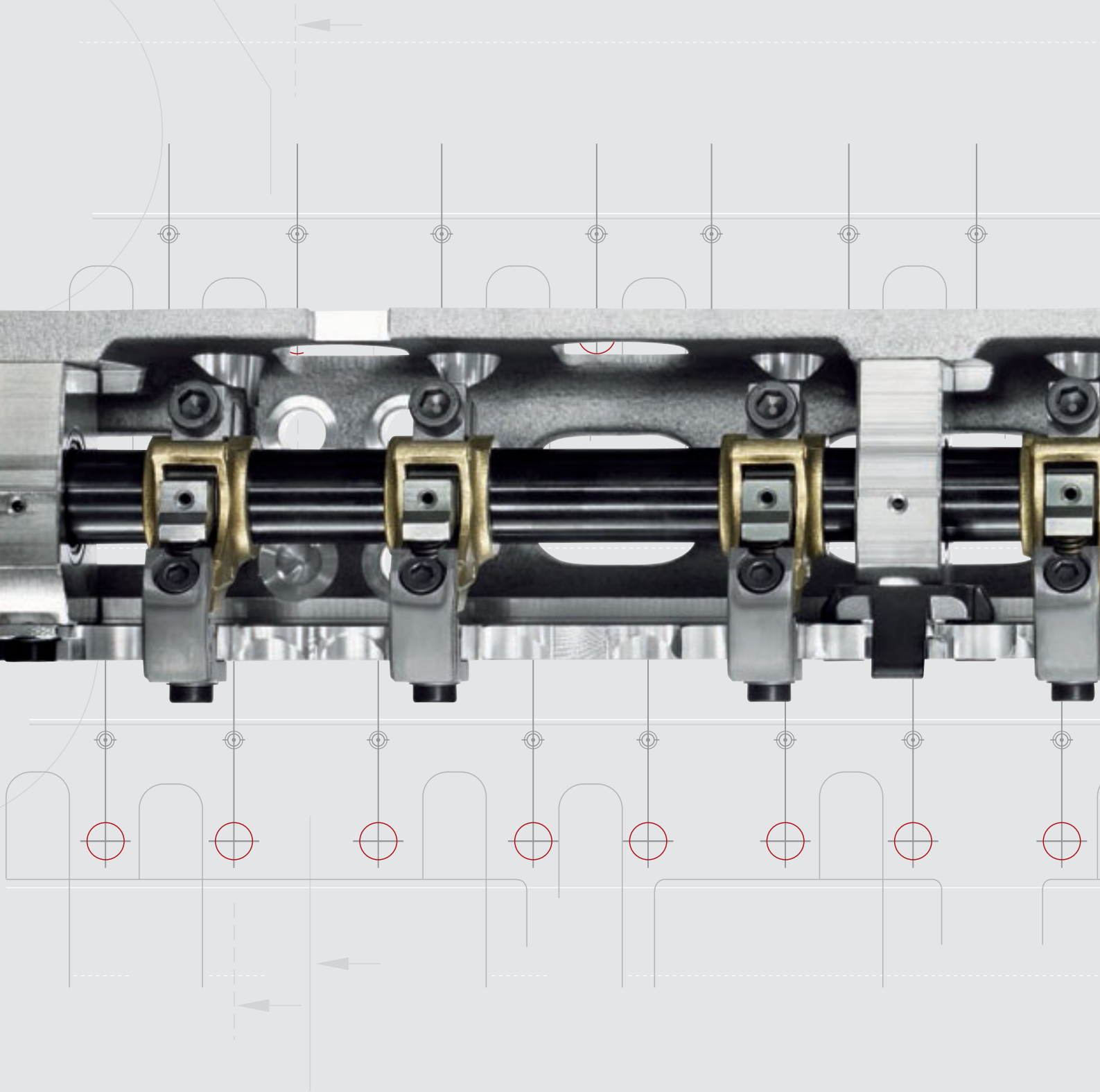

Heidelberger Druckmaschinen AG

Kurfuersten-Anlage 52 – 60

69115 Heidelberg

Germany

www.heidelberg.com

HEIDELBERG